



OPENING ITEMS

APPROVAL OF AGENDA

APPROVAL OF MINUTES

1. Consider Approval of the Minutes from the Regular Meeting and Work Session Held on October 11, 2022

PUBLIC HEARING

2. Property Tax Abatement for Daisy and Tulip Holdings LLC 1) Public Hearing on Assessment; 2) Consider Resolution Granting Abatement

AWARD OF BIDS

CONSENT AGENDA

3. Introduction of Ordinance Amendment to Chapter 86, Article VI-1, Section 86-165 Structures in Residential Districts and Call for Public Hearing
4. Consider Authorization to Declare Vehicles as Surplus Property for the Marshall Police Department
5. Consider Request of Prairie Home Hospice & Community Care for the Light Up the Night Parade on Friday, November 25, 2022
6. MPCA Memorandum of Understanding (MOU) for PFAS Monitoring Plan (Per- and Polyfluoroalkyl Substances)
7. Contract with State of Minnesota and the City of Marshall for HAZMAT Services to Southwest Minnesota
8. Consider Approval of the Bills/Project Payments

APPROVAL OF ITEMS PULLED FROM CONSENT

OLD BUSINESS

TABLED ITEM

NEW BUSINESS

9. Marshall Fire Department Aerial Apparatus Replacement
10. 2023 FEMA Assistance to Fire Fighters Grant
11. Consider Health and Dental Insurance renewals for 2023
12. Project ST-015 / SP 4204-40): 2025 MnDOT College Drive Improvement Project - Consider Resolution for Municipal Consent and Layout Approval

COUNCIL REPORTS

13. Commission/Board Liaison Reports
14. Councilmember Individual Items

STAFF REPORTS

15. City Administrator
16. Director of Public Works/City Engineer
17. City Attorney

ADMINISTRATIVE REPORTS

INFORMATION ONLY

18. Library Board September Minutes
19. Cash and Investments
20. Kissimmee Utility Authority Board of Directors Letter
21. Building Permits

ADJOURN TO CLOSED SESSION

MEETINGS

ADJOURN

Disclaimer: These agendas have been prepared to provide information regarding an upcoming meeting of the Common Council of the City of Marshall. This document does not claim to be complete and is subject to change.



CITY OF MARSHALL AGENDA ITEM REPORT

Presenter:	Mayor Brynes
Meeting Date:	Tuesday, October 25, 2022
Category:	APPROVAL OF MINUTES
Type:	ACTION
Subject:	Consider Approval of the Minutes from the Regular Meeting and Work Session Held on October 11, 2022
Background Information:	Enclosed are the minutes from the regular meeting and work session held on October 11, 2022.
Fiscal Impact:	
Alternative/ Variations:	Staff encourages City Council Members to provide any suggested corrections to the minutes in writing to City Clerk, Steven Anderson, prior to the meeting.
Recommendations:	That the minutes from the regular meeting held on October 11, 2022, be approved as filed with each member and that the reading of the same be waived.

**CITY OF MARSHALL
CITY COUNCIL MEETING
M I N U T E S
Tuesday, October 11, 2022**

The regular meeting of the Common Council of the City of Marshall was held October 11, 2022, at City Hall, 344 West Main Street. The meeting was called to order at 5:30 P.M. by Mayor Robert Byrnes. In addition to Byrnes the following members were in attendance: Craig Schafer, Amanda Schroeder, Steve Meister, John DeCramer, Russ Labat and James Lozinski. Absent: None. Staff present included: Sharon Hanson, City Administrator; Dennis Simpson, City Attorney; Jason Anderson, Director of Public Works/City Engineer; E.J. Moberg, Director of Administrative Services; Sheila Dubs, Human Resource Manager; Laura Wing, Payroll/Benefits Specialist; Scott Truedson, Wastewater Superintendent and Steven Anderson, City Clerk.

The Pledge of Allegiance was recited at this time.

Consider Approval of the Minutes from the Regular Meeting Held on September 27, 2022

Councilmember Labat requested that the motion be amended for the fire department grass rig purchase to include language that the fire department request ARPA funds from Lyon County.

Motion made by Councilmember Schafer, Seconded by Councilmember Schroeder to approve the minutes with the included amendment. Voting Yea: Mayor Byrnes, Councilmember Schafer, Councilmember Meister, Councilmember DeCramer, Councilmember Labat, Councilmember Lozinski, Councilmember Schroeder. The motion **Carried. 7-0.**

Project Z83: James Avenue/Camden Drive Reconstruction Project - 1) Public Hearing on Assessment; 2) Consider Resolution Adopting Assessment

Director of Public Works/City Engineer Jason Anderson presided over the public hearing for project Z83: James Avenue/Camden Drive Reconstructions. The project was completed in the 2021 construction season. 7.2% of the project costs are going towards special assessments to landowners, 7.9% comes from the wastewater fund, 12.5% from MMU, 51.6% from surface water management utility and the remainder from the city general fund. The total project amounted to \$995,217.78. Anderson indicated that he did receive a couple comments right before the council meeting, but the issue was resolved, and no formal objection was filed. Mayor Byrnes opened the public hearing for comments and no comments were made by the public.

Motion made by Councilmember Meister, Seconded by Councilmember DeCramer to close the public hearing. Voting Yea: Mayor Byrnes, Councilmember Schafer, Councilmember Meister, Councilmember DeCramer, Councilmember Labat, Councilmember Lozinski, Councilmember Schroeder. The motion **Carried. 7-0.**

Motion made by Councilmember Schafer, Seconded by Councilmember Labat to adopt the assessment resolution. Voting Yea: Mayor Byrnes, Councilmember Schafer, Councilmember Meister, Councilmember DeCramer, Councilmember Labat, Councilmember Lozinski, Councilmember Schroeder. The motion **Carried. 7-0.**

Public Hearing for an On-Sale and Sunday Liquor License Application for Atlantic Place

City Ordinance requires that an on-sale liquor license can only be at one physical address per license. As Atlantic Place has now taken over the former Bello Cucina location the city needs to transfer the license from Bello Cucina to Atlantic Place. Councilmember Schafer asked for clarification on Knockenmus Enterprises and Atlantic Place. Knockenmus Enterprises originally applied for a liquor license but had since switched business names for the new restaurant and did not submit the original liquor license. The liquor license fee will be prorated for Atlantic Place. No further public comments were made.

Motion made by Councilmember Schafer, Seconded by Councilmember Lozinski to close the public hearing. Voting Yea: Mayor Byrnes, Councilmember Schafer, Councilmember Meister, Councilmember DeCramer, Councilmember Labat, Councilmember Lozinski, Councilmember Schroeder. The motion **Carried. 7-0.**

Public Hearing for an On-Sale Liquor License Application for The Gambler

Like the previous public hearing City Ordinance requires than an on-sale liquor license can only be at one physical address per license. SLB Enterprises LLC has taken ownership of the Gambler and the city now needs to transfer the license from Pearcy Enterprises LLC to SLB Enterprises LLC. No public comments were made.

Motion made by Councilmember DeCramer, Seconded by Councilmember Meister to close the public hearing. Voting Yea: Mayor Byrnes, Councilmember Schafer, Councilmember Meister, Councilmember DeCramer, Councilmember Labat, Councilmember Lozinski, Councilmember Schroeder. The motion **Carried. 7-0.**

Consider Award of Bid for the Pickup of Refuse for Various City Locations

City Clerk, Steven Anderson presented the bids received on October 6th, 2022, for refuse collection at various city locations. Two bids were received, Southwest Sanitation and Waste Management. An additional bid was solicited from West Central Sanitation, but no bid was received. The low bid of \$30,360.44 came from Southwest Sanitation and is the recommendation for acceptance. Councilmembers had questions on a couple facilities and refuse needs. Scott Truedson, Wastewater Superintendent, gave details to council on why the wastewater portion of the bid had an increase much higher than other locations.

Motion made by Councilmember Schafer, Seconded by Councilmember Labat to accept the bid from Southwest Sanitation for refuse collection. Voting Yea: Mayor Byrnes, Councilmember Schafer, Councilmember Meister, Councilmember DeCramer, Councilmember Labat, Councilmember Lozinski, Councilmember Schroeder. The motion **Carried. 7-0.**

Approval of the Consent Agenda

Councilmember Labat asked that agenda item number 10) Call for a Public Hearing Regarding Proposed Property Tax Abatement for Daisy and Tulip Holdings LLC be pulled from consent.

Motion made by Councilmember Meister, Seconded by Councilmember Schafer to approve the remaining consent items. Voting Yea: Mayor Byrnes, Councilmember Schafer, Councilmember Meister, Councilmember DeCramer, Councilmember Labat, Councilmember Lozinski, Councilmember Schroeder. The motion **Carried. 7-0.**

- Consider Resolution Increasing the Marshall Fire Department Relief Assoc. Benefit Level
- Consider a Resolution Designating Uniform Election Dates and Polling Locations for 2023
- Consider an Application for a LG220 Gambling Permit for a Raffle at SMSU Gold Rush Days
- Consider an Application for a Temp On-Sale License for SMSU Gold Rush Days
- Consider Approval of Agreements with Cigna and Hartford for Voluntary Employee Supplemental Benefits
- Consider Approval of the Bills/Project Payments

APPROVAL OF ITEMS PULLED FROM CONSENT

Councilmember Labat had a question on the length of time for the tax abatement. It was clarified that the term is for 4 years not the 10-year maximum that is allowed that was indicated on a portion of the calculation page.

- Call for a Public Hearing Regarding Proposed Property Tax Abatement for Daisy and Tulip Holdings LLC

Motion made by Councilmember Labat, Seconded by Councilmember Meister to approve the call for public hearing regarding proposed property tax abatement. Voting Yea: Mayor Byrnes, Councilmember Schafer, Councilmember Meister, Councilmember DeCramer, Councilmember Labat, Councilmember Lozinski, Councilmember Schroeder. The motion **Carried. 7-0.**

Consider a Quote to Upgrade the Camera System and Recording Server at Tall Grass Liquor

E.J. Moberg, Director of Administrative Services, explained the details for the quote from Living Connected. Liquor Store Manager Erik Luther had previously discussed security upgrades and additions with Moberg in September. The quote is for six additional cameras, an upgraded recording server to accommodate the existing cameras and the proposed new ones. The camera upgrade would allow for better image quality, storage capacity and better coverage inside and outside the store. The quote received from Living Connected is good for 20 days due to fluctuating pricing and availability. The purchase would be through the liquor stores cash on hand. Council had questions on the specifications of the proposed cameras.

Motion made by Councilmember Schafer, Seconded by Councilmember DeCramer. Voting Yea: Mayor Byrnes, Councilmember Schafer, Councilmember Meister, Councilmember DeCramer, Councilmember Labat, Councilmember Lozinski, Councilmember Schroeder. The motion **Carried. 7-0.**

Consider Appointments to Various Boards, Commission, Bureaus, and Authorities

Mayor Byrnes recommended Benjamin Blomme to the EDA with a term ending May 31, 2023. Two interviews for the EDA were conducted on September 27, 2022. Councilmember Meister explained the unusualness of having two applicants for an open position. Council encouraged the public to look for the open positions with the city and apply.

Motion made by Councilmember DeCramer, Seconded by Councilmember Schafer. Voting Yea: Mayor Byrnes, Councilmember Schafer, Councilmember Meister, Councilmember DeCramer. Voting Nay: Councilmember Lozinski. Voting Abstaining: Councilmember Labat, Councilmember Schroeder. The motion **Carried. 4-1-2.**

Commission/Board Liaison Reports

- | | |
|-----------|---|
| Byrnes | The Fire Relief Association has an upcoming quarterly meeting. Regional Development will meet on Thursday. |
| Schafer | No report. |
| Meister | EDA met, and discussions were had with a developer for the mall. |
| Schroeder | No report. |
| DeCramer | MMU has not met yet, but three members from MMU were in Florida assisting with disaster recovery from the hurricane. DEI met and reviewed the Welcome Week event. To a great surprise for the DEI committee a grant was received that covered the expenses for the whole event. |
| Labat | Library met and talked about increasing room rental rates. The van owned by the library remains unsold and new avenues are being investigated to sell the vehicle. The libraries new Aspen Discovery, online catalog, system is up and running. |
| Lozinski | No report. |

Councilmember Individual Items

Councilmember Labat thanked Public Works for follow-up on some mowing concerns.

Councilmember DeCramer attended Star Watch with Mike Lynch at Patriot Park, the event was well received and had a large crowd.

Mayor Brynes mentioned that last week the 150th Anniversary Book unveiling was the final event for the City of Marshall's 150th Anniversary.

City Administrator

Staff and the Mayor met regarding the census appeal and hopes to have something prepared for the next council meeting.

Director of Public Works/City Engineer

Updates were given on the following street projects within the city: 1st and Greeley reconstructions; Halbur Road is planned to be open by the end of the week, construction was to have been finished by the end of September; the Baldwin Parking lot which is directly behind the city hall is currently in progress and concrete is planned to be poured the week of October 17th; and the signage for the RRFB project are supposed to be arriving shortly. Bids for Channel Parkway surfacing are due October 20th.

City Attorney

A mediation session is scheduled with the Minnesota Attorney General's office on Friday the 14th to come to an agreement with Paul Schierholz on outstanding Broadmoor Valley issues.

Administrative Brief

There were no questions on the Administrative Brief.

Informational Only

There were no questions on the Informational Only items.

Upcoming Meetings

There were no questions on Upcoming Meetings.

Adjourn

At 6:05 PM Motion made by Councilmember Schafer, Seconded by Councilmember Lozinski to adjourn the meeting. Voting Yea: Mayor Byrnes, Councilmember Schafer, Councilmember Meister, Councilmember DeCramer, Councilmember Labat, Councilmember Lozinski, Councilmember Schroeder. The motion **Carried. 7-0.**

**CITY OF MARSHALL
WORK SESSION
M I N U T E S
Tuesday, October 11, 2022**

The work session of the Common Council of the City of Marshall was held October 11, 2022, at City Hall, 344 West Main Street. The meeting was called to order at 4:00 P.M. by Mayor Robert Byrnes. In addition to Byrnes the following members were in attendance: Steve Meister, John DeCramer, Russ Labat, James Lozinski, and Amanda Schroeder. Absent: Craig Schafer. Staff present included: Sharon Hanson, City Administrator; E.J. Moberg, Director of Administrative Services; Sheila Dubs, Human Resource Manager; Laura Wind, Payroll/Benefits Specialist and Steven Anderson, City Clerk.

Councilmember Schafer arrived at 4:02pm.

2023 Health and Dental Insurance Renewal for 2023

For 2022-2023, the Council approved a 2-year commitment with Blue Cross Blue Shield (BCBS), resulting in a 12% decrease in premiums compared to the rates offered by Public Employee Insurance Program (PEIP) for 2022. The agreement with BCBS included a maximum rate cap in the 2nd year (2023) of 11%.

Sheila Dubs, Human Resource Manager, introduce Bill Chukuske from National Insurance Services who presented the 2023 renewals to council. Chukuske went over the 2023 benefits rates and indicated he was able to negotiate a reduced rate increase of 8.8% for 2023 for medical insurance. A history of the City's premium renewals and claims data was reviewed by Chukuske. Dental insurance for 2022-2023, the Council approved a 2-year commitment with Delta Dental, with no increase in premium rates for 2023. Staff reviewed City of Marshall's comparable city's health and dental information and a cost-share proposal for 2023 at the work session.

HR Staff plans to come back to council during the regular meeting on October 25 for council to consider approval of premium cost-sharing for health and dental insurances. An employee benefits fair is planned for October 31 and Open Enrollment is planned for November 1-14. Employees will make their individual benefit elections on-line.

Adjourn

At 4:33 P.M. Mayor Brynes adjourned the work session.

Mayor

Attest:

City Clerk

**CITY OF MARSHALL
AGENDA ITEM REPORT**

Meeting Date:	Tuesday, October 25, 2022
Category:	CONSENT AGENDA
Type:	ACTION
Subject:	Public Hearing Regarding Proposed Property Tax Abatement for Daisy and Tulip Holdings LLC
Background Information:	<p>Daisy and Tulip Holdings LLC (D & G Excavating, Inc. is requesting a commercial tax abatement for a storage facility the company will be building in the Centrol Addition. They intend to build a 60' x 120' storage building for the purpose of storing snow removal equipment.</p> <p>Previously D & G has rented space in Marshall for this purpose, but recent sales of these buildings has removed the option to lease. In order to continue snow removal service (currently 85 properties being served) which keeps their seasonal staff employed year-round, the new storage space is necessary.</p> <p>The abatement request is for \$6,928.00 over four years.</p>
Fiscal Impact:	\$6,928.00
Alternative/ Variations:	None
Recommendations:	1) Close the public hearing. 2) Approve the proposed property tax abatement for Daisy and Tulip Holdings, LLC

D & G Excavating

**CALCULATING 2021 EMV AS BASE - ONLY HAVING ABATEMENT
ON IMPROVEMENT EMV**

	EMV	City Taxes	County Taxes	TOTAL TAX BILL
Base EMV	\$ 76,300.00	\$ 675.00	\$ 429.00	\$ 1,585.00
Improvement EMV	\$ 311,900.00	\$ 3,464.00	\$ 1,839.00	\$ 9,999.00
Total EMV	\$ 388,200.00	\$ 4,139.00	\$ 2,268.00	\$ 11,584.00

BASED ON OFFICE ESTIMATE	1	2	3	4		
year	2024	2025	2026	2027		
ENTER % OF ABATEMENT HERE ➔	80%	60%	40%	20%		
Base EMV Captured Taxes	\$ 675.00	\$ 675.00	\$ 675.00	\$ 675.00		
Improvement EMV Abated Taxes	\$ 2,771.20	\$ 2,078.40	\$ 1,385.60	\$ 692.80		
Improvement EMV Captured Taxes	\$ 692.80	\$ 1,385.60	\$ 2,078.40	\$ 2,771.20		
	TOTAL (4 Year)					
Amount of Abatement	\$ 2,771.20	\$ 2,078.40	\$ 1,385.60	\$ 692.80	\$ 6,928.00	REQUESTED \$\$\$ \$ -
Amount of Taxes the City receives	\$ 1,367.80	\$ 2,060.60	\$ 2,753.40	\$ 3,446.20	\$ 34,462.00	BALANCE OF \$ -
Total Tax Bill (city)	\$ 4,139.00	\$ 4,139.00	\$ 4,139.00	\$ 4,139.00	\$ 41,390.00	SPECIALS FORGAVE \$ - TAX ABATEMENT \$ - \$ 6,928.00

CITY OF MARSHALL
NOTICE OF PUBLIC HEARING REGARDING PROPOSED PROPERTY TAX ABATEMENT
FOR TAX ABATEMENT APPLICANT DAISY AND TULIP HOLDINGS LLC

NOTICE IS HEREBY GIVEN that the City Council of the City of Marshall Minnesota (the “City”), will hold a public hearing at a meeting of the Council beginning at or after 5:30 p.m., on October 25, 2022 to be held in the Council Chambers at City Hall, 344 West Main St. in Marshall, Minnesota, on the request of a Tax Abatement Applicant that the City abate a portion of property taxes levied by the City in connection with the proposed construction of a new structure. The property is located within the City and is currently identified as Parcel No. 27-158001-0. The approximate amount of assistance is \$6,928.00 over a maximum period of 4 years. The City Council will consider granting a property tax abatement in response to the request.

Information about the proposed tax abatement will be on file and available for public inspection at the office of the City Clerk at City Hall.

All interested persons may appear at the public hearing and present their views orally or in writing. Following the public hearing, the City Council will take action concerning the adoption or rejection of the proposed tax abatement application.

October 14, 2022

Steven Anderson
City Clerk

Resolution Number 22-084

RESOLUTION RELATING TO A TAX ABATEMENT ON PROPERTY BY DAISY AND TULIP HOLDINGS LLC; GRANTING THE ABATEMENT

BE IT RESOLVED by the Common Council of the City of Marshall, Minnesota, as follows:

Section 1. AUTHORIZATION AND RECITALS.

- 1.01. The City, pursuant to Minnesota Statutes, Sections 469.1812 to 469.1815, as amended (the "Act"), is authorized to grant an abatement of the property taxes imposed by the County on a parcel of property (Property Tax Abatement) if certain conditions are met, through the adoption of a resolution specifying the terms of the abatement.
- 1.02. The City has adopted the City of Marshall Tax Abatement Policy which further stipulates requirements before an abatement of taxes will be granted for residential development.
- 1.03. Daisy and Tulip Holdings LLC; have applied for a Home Tax Abatement pursuant to the City's Home Tax Abatement Policy on property legally described as: Parcel ID: 27-158001-0.
- 1.04. Pursuant to the Act, this Common Council on October 25, 2022 conducted a public hearing on the desirability of granting the abatement. Notice of the public hearing was duly published as required by law in the Marshall Independent, the official newspaper of the City.

Section 2. FINDINGS. On the basis of information compiled by the City and elicited at the public hearing referred to in Section 1.04, it is hereby found, determined and declared:

- 2.01. There is a need for new development on the Property to increase the tax base of the City and to improve the general economy of the state.
- 2.02. The granting of the proposed abatement is in the public interest because it will increase or preserve the tax base of the City.
- 2.03. The Property is not located in a tax increment financing district.
- 2.04. The granting of the proposed abatement will not cause the aggregate amount of abatements granted by the City under the Act to exceed the greater of ten percent (10.00%) of the County's current property tax levy, or \$200,000.
- 2.05. It is in the best interests of the City to grant the tax abatement authorized in this Resolution.

Section 3. GRANTING OF TAX ABATMENT

- 3.01. A property tax abatement (the "Abatement") is hereby granted in respect of property taxes levied by the City on the Property for four (4) years, commencing with taxes payable for the assessed value related to the capital improvements outlined in 1.03.

3.02. The City shall provide the awarded abatement payment following payment of due real estate taxes annually. One single payment shall be made to the owner of record by December 30th of that calendar year.

3.03 The tax abatement shall be for the commercial capital improvements only. Land values and the current base value are not eligible and will not be abated.

3.04. The Abatement may be modified or terminated at any time by the Common Council in accordance with the Act.

3.05. The Abatement total is estimated to be approximately \$6,928.00 and should not exceed that amount. The Abatement scale approved is as follows:

Year 1	80% Abatement
Year 2	60% Abatement
Year 3	40% Abatement
Year 4	20% Abatement

Passed by the Common Council of the City of Marshall, this 25th day of October 2022.

Mayor

ATTEST:

City Clerk

**CITY OF MARSHALL
AGENDA ITEM REPORT**

Presenter:	Ilya Gutman
Meeting Date:	Tuesday, October 25, 2022
Category:	CONSENT AGENDA
Type:	INFO/ACTION
Subject:	Introduction of Ordinance Amendment to Chapter 86, Article VI-1, Section 86-165 Structures in Residential Districts and Call for Public Hearing
Background Information:	<p>The current ordinance prohibits exterior finishes with exposed fasteners on non-accessory structures in all residential districts to avoid industrial looking buildings and protect the values of the properties. However, it appears that those fasteners on low slope roofs (with less than 4 in 12 pitch) are practically not visible. Considering that metal roofs with exposed fasteners may be a practical alternative to shingles in this situation, it would be reasonable to allow it.</p> <p>At the September 14, 2022, regular Planning Commission meeting, Deutz made a motion, second by Muchlinski to recommend to city council an approval as recommend by staff. All voted in favor of the motion.</p> <p>At the meeting on October 11, 2022, Legislative and Ordinance Committee voted to revise staff recommendation and to allow exposed fasteners on all roofs and then recommend to City Council introducing the amendments to Chapter 86, Article VI-1, Section 86-165 Structures in Residential Districts.</p>
Fiscal Impact:	None.
Alternative/ Variations:	Consider recommendation by staff to permit exposed fasteners on low slope roofs only.
Recommendations:	Staff recommends that the Council introduce the amendments to Chapter 86, Article VI-1, Section 86-165 Structures in Residential Districts and Call for Public Hearing to be held on November 7, 2022.

Section 86-165 Structures In Residential Districts

For all permitted non-accessory structures in the R-1, R-2, R-3 and R-4 Districts, the following shall apply:

- (a) Such structures shall comply with all applicable zoning regulations for the zone in which they are located and with all applicable state statutes and codes.
- (b) A building permit and any other required permits shall be obtained for such structures.
- (c) No such structures shall have a footprint of less than 800 square feet, not including an attached garage, unless such garage has habitable space above.
- (d) No such structures shall have a dimension of less than 24 feet at its narrowest point, as measured from faces of exterior walls, in any direction, except entries, porches, and similar attachments.
- (e) Any such structure shall be placed on permanent building code compliant foundation that is continuous around the entire perimeter of the building except for decks, porches, or similar attached structures or rooms constituting less than 25 percent of the building footprint area.
- (f) Any such structure shall have exterior wall finish materials extend down to foundation or within 12 inches above grade, whichever is less. Wainscoting, if used, shall be minimum of 36 inches high.
- (g) Any such structure shall have a sloped roof with at least 3/12 pitch over at least half of the building; a flat roof is permitted over entire buildings larger than 1,200 square feet in footprint or taller than two stories.
- (h) No such structure shall use materials with exposed fasteners as an exterior finish, except sloped roofs.
- (i) In R-1 one family residence district, direct and independent connection to city utilities shall be required for each such structure and no exterior fuel tanks shall be allowed, except one tank, 50 gallons or less, properly located and screened, may be permitted.
- (j) In R-1 one-family residence district, not more than one such structure may be built on a single lot.
- (k) Nothing in this article shall prevent the regulation of uses of property by means of restrictive covenants.

(Code 1976, § 11.19(5); Ord. No. 732 2nd Series, § 1, 1-8-2019)

State law reference(s)—Manufactured home park to be conditional use in any district allowing buildings used or intended to be used by two or more families, Minn. Stat. § 462.357, subd. 1b.

ORDINANCE NO. 22-_____

AN ORDINANCE AMENDING
MARSHALL CITY CODE OF ORDINANCES – CHAPTER 86
RELATING TO ZONING

The Common Council of the City of Marshall does ordain as follows:

Section 1: City Code of Ordinances Chapter 86, Article VI-1, Section 86-165 Structures in Residential Districts, (h) is hereby amended as follows:

CHAPTER 86 ZONING
ARTICLE 86-VI SUPPLEMENTAL REGULATIONS
DIVISION 86-VI-1 GENERALLY

Section 86-165 Structures In Residential Districts

- (h) No such structure shall use materials with exposed fasteners as an exterior finish, except sloped roofs.

Section 2: This Ordinance shall take effect after their passage and summary publication.

Passed and adopted by the Common Council this 7th day of November 7, 2022.

THE COMMON COUNCIL

ATTEST:

Mayor of the City of Marshall, MN

City Clerk

Introduced on: October 25, 2022

Final Passage on: November 7, 2022

Published in the Marshall Independent: _____



CITY OF MARSHALL AGENDA ITEM REPORT

Presenter:	Jim Marshall
Meeting Date:	Tuesday, October 25, 2022
Category:	CONSENT AGENDA
Type:	ACTION
Subject:	Consider authorization to declare vehicles as surplus property for the Marshall Police Department.
Background Information:	These vehicles have been abandoned or seized by the Marshall Police Department and have gone through the notification processes and required periods for disposal.
Fiscal Impact:	These vehicles will be auctioned on-line at the state site, sold, or will be taken to Alters for disposal.
Alternative/ Variations:	
Recommendations:	That these vehicles be declared as surplus property by the City of Marshall.

22-1885	01 Chevy Malibu	684 XGT	1G1NDS2J416244027	Forf (Co Atty)
21-13377	07 Chev Suburban	FJU 975	1GNFK16397J319887	Forf (Co Atty)
19-18374	11 Ford Taurus	CZX 346	1FAHPZEWXBG169918	Forf (Co Atty)

**CITY OF MARSHALL
AGENDA ITEM REPORT**

Presenter:	Jason Anderson
Meeting Date:	Tuesday, October 25, 2022
Category:	CONSENT AGENDA
Type:	ACTION
Subject:	Consider Request of Prairie Home Hospice & Community Care for the Light Up The Night Parade on Friday, November 25, 2022.
Background Information:	<p>The City has received the attached request from Prairie Home Hospice & Community Care for street closure on Main Street (US 59) from North 6th Street to E. Lyon Street and E. Lyon Street from E. Main Street to Parkside School near Adobe Road from 5:00 pm-7:30 pm for the Light Up The Night Parade to be held on Friday, November 25, 2022.</p> <p>The parade will start at North 5th Street (Wooden Nickel corner) and proceed down Main Street (US59) to East Lyon Street and then down East Lyon Street toward Independence Park ending at Parkside Elementary.</p> <p>A copy of the parade route/detour map is attached.</p> <p>Upon approval of the City Council, the request will be forwarded to Mn/DOT for their approval of the State permit.</p>
Fiscal Impact:	None.
Alternative/ Variations:	No alternative actions recommended.
Recommendations:	that the Council authorize the Light Up The Night Parade to be held on Friday, November 25, 2022, subject to Mn/DOT approval of detour and issuance of permit.



APPLICATION FOR PERMIT FOR PRIVATE USE OF PUBLIC STREETS (RIGHTS-OF-WAY) AND PARKING LOTS

Applicant Name: Prairie Home Hospice & Community Care

Applicant Address: 1108 E College Dr, Marshall MN 56258

Contact Person: Cory Brockman Phone/Cell#: 507-530-4580

Address of Request: Main Street / Lyon Street

Reason for Request: Light Up The Night

Start Date of Request: November 25, 2022 Start Time: 5:00 am/pm

End Date of Request: November 25, 2022 End Time: 7:30 am/pm

Brief Description of Area Requested for Private Use/Closure (attach map): Main Street (Highway 59) from South 6th St (Marshall Independent) to Lyon Street and down Lyon Street to Independence Park (end @ Parkside Elementary)

Does the request involve Mn/DOT Right-of-Way? Yes No

The Applicant agrees to assume entire responsibility and liability for all damages or injury to all persons, whether employees or otherwise and to all property, arising out of, resulting from or in any manner connected with the operation of the event.

The Applicant agrees to indemnify the City, its agents and employees from all such claims including, without limiting the generality of the foregoing claims for which the City may be or may be claimed to be liable, and legal fees and disbursements paid or incurred to enforce the provisions this paragraph.

The Applicant will be responsible for any damage done to the public property as a result of the event activities, damages payable upon receipt of invoice.

It is the responsibility of the Applicant to install and maintain the appropriate traffic control devices during the closure period. Traffic control devices shall be in conformance with the Minnesota Manual on Uniform Traffic Control Devices, MUTCD.

If the event or private use area occurs within Mn/DOT right-of-way:

- 1. Participants and event officials will obey all Minnesota Laws pertaining to the use of Highway Rights of Way.
2. The event officials will notify the Minnesota State Patrol of the proposed event and will provide law enforcement officers to control and/or detour trunk highway traffic affected by the event.

Date 9/26/2022

Signature of Applicant [Signature]

DETOUR SIGNING PLAN

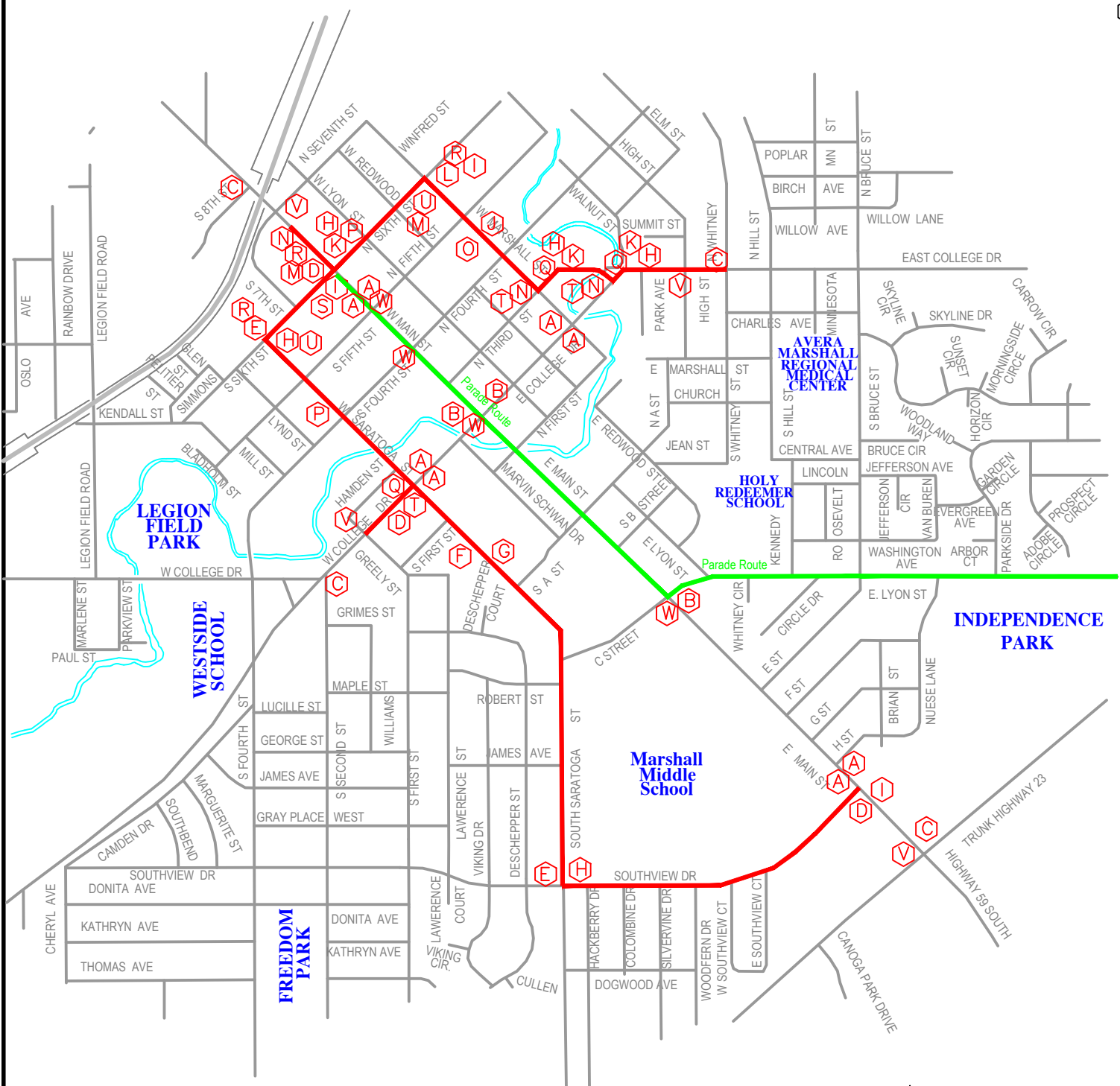

Red Line: CITY OF MARSHALL DETOUR ROUTE
Green Line: PARADE ROUTE

THIS MAP SHOWS DETOUR ROUTE CLOSURES ON STATE AND US HIGHWAYS. ALL LOCAL SIDE STREETS WILL ALSO BE CLOSED WITH NO TRAFFIC ALLOWED WITHIN CLOSED ROAD.

ALL TRAFFIC CONTROL DEVICES SHALL CONFORM TO THE LATEST EDITION OF THE MINNESOTA MANUAL ON UNIFORM TRAFFIC CONTROL DEVICES, INCLUDING THE LATEST FIELD MANUAL FOR TEMPORARY TRAFFIC CONTROL ZONE LAYOUTS

ALL NECESSARY TRAFFIC CONTROL DEVICES AND DETOUR DEVICES FOR THIS PROJECT SHALL BE THE RESPONSIBILITY OF THE CITY OF MARSHALL. ALL TRAFFIC CONTROL DEVICES SHALL HAVE RETROREFLECTIVE SHEETING.











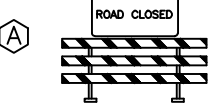
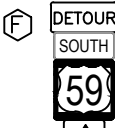
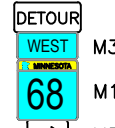

Item 5.

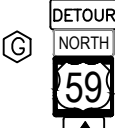
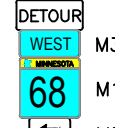

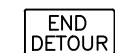

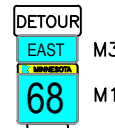
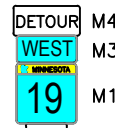
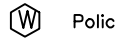

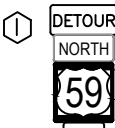
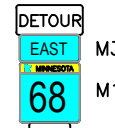
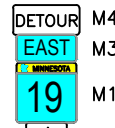
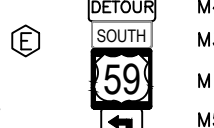
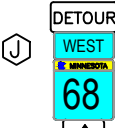
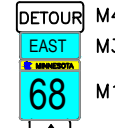

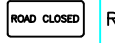

CITY OF MARSHALL
 LYON COUNTY
 MINNESOTA



NOT TO SCALE

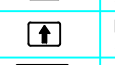
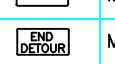

CITY ENGINEERS OFFICE
 344 WEST MAIN STREET
 MARSHALL, MINNESOTA
 56258

 R11-2 G20-2 FLASHERS NOT SHOWN	 M4-8 M3-3 M1-4-US59 M6-3	 M4-8 M3-4-024BL M1-5M-MN68-024BL M5-1R-021BL	 M4-8 M3-4-024BL M1-5M-MN19-024BL M6-3-021BL	 M4-8 M3-2-024BL M1-5M-MN19-024BL M5-1R-021BL
 G20-2 FLASHERS NOT SHOWN	 M4-8 M3-1 M1-4-US59 M6-3	 M4-8 M3-4-024BL M1-5M-MN68-024BL M5-1L-021BL	 M4-8 M3-4-024BL M1-5M-MN19-024BL M5-1R-021BL	 M4-8a *500' FROM INT.
 W20-2 1500 FEET *1500' FROM INT.	 M4-8 M3-1 M1-4-US59 M5-1R	 M4-8 M3-2-024BL M1-5M-MN68-024BL M5-1R-021BL	 M4-8 M3-4-024BL M1-5M-MN19-024BL M5-1L-021BL	 Police
 M4-8 M3-3 M1-4-US59 M5-1R	 M4-8 M3-1 M1-4-US59 M5-1L	 M4-8 M3-2-024BL M1-5M-MN68-024BL M5-1L-021BL	 M4-8 M3-2-024BL M1-5M-MN19-024BL M6-3-021BL	
 M4-8 M3-3 M1-4-US59 M5-1L	 M4-8 M3-4-024BL M1-5M-MN68-024BL M6-3-021BL	 M4-8 M3-2-024BL M1-5M-MN68-024BL M6-3-021BL	 M4-8 M3-2-024BL M1-5M-MN19-024BL M5-1L-021BL	

SIGN	SIGN NO.	QUANTITY	SIZE	COLOR	FLASHERS
	TYPE III BARRICADE	11	60"x48"	ORANGE ON WHITE	19
	R11-3	8	60"x30"	BLACK ON WHITE	
	W20-2	4	36"x36"	BLACK ON ORANGE	
	M1-4	15	24"x24"	BLACK ON WHITE	
	M1-5M-MN68-024BL	11	24"x24"	WHITE AND GOLD ON BLUE	
	M1-5M-MN19-024BL	14	24"x24"	WHITE AND GOLD ON BLUE	
	W20-100P	4	30"x24"	BLACK ON ORANGE	
	M3-2-024BL	12	24"x24"	WHITE ON BLUE	
	M3-4-024BL	13	24"x24"	WHITE ON BLUE	
	M5-1R-021BL	10	21"x15"	WHITE ON BLUE	
	M5-1L-021BL	10	21"x15"	WHITE ON BLUE	
	M6-3-021BL	5	21"x15"	WHITE ON BLUE	
	M4-8	40	24"x12"	BLACK ON ORANGE	
	M4-8a	4	24"x18"	BLACK ON ORANGE	

SIGN	SIGN NO.	QUANTITY	SIZE	COLOR
	M3-1	9	24"x24"	BLACK ON WHITE
	M3-3	6	24"x24"	BLACK ON WHITE
	M5-1R	8	21"x15"	BLACK ON WHITE
	M5-1L	5	21"x15"	BLACK ON WHITE
	M6-3	2	21"x15"	BLACK ON WHITE

Light up the Night Parade

Detour Plan

REVISIONS	
DATE	DESCRIPTION

I HEREBY CERTIFY THAT THIS PLAN, SPECIFICATION OR REPORT WAS PREPARED BY ME OR UNDER MY DIRECT SUPERVISION AND THAT I AM A DULY LICENSED ENGINEER UNDER THE LAWS OF THE STATE OF MINNESOTA.

DATE _____ REGISTRATION NO. 41557

DATE 02/23/2022

DRAWN BY G.J.S.

S.P. NO.

SHEET Page 20

**CITY OF MARSHALL
AGENDA ITEM REPORT**

Presenter:	Jason Anderson
Meeting Date:	Tuesday, October 25, 2022
Category:	CONSENT AGENDA
Type:	ACTION
Subject:	MPCA Memorandum of Understanding (MOU) for PFAS Monitoring Plan (Per- and Polyfluoroalkyl Substances).
Background Information:	<p>The MPCA has been in discussion with selected Wastewater Treatment Facilities (WWTFs) regarding PFAS monitoring for nearly a year. The MPCA had requested input concerning their original MOU agreement and, after receiving feedback, has made a few changes. Probably the most notable item is on page 8 of the attached MOU where it says that the MPCA will, for those facilities that sign the MOU, pay for the collection and analysis of the first two samples. They also say that they will try to secure funding for the final two sampling events in 2024.</p> <p>Several of the following changes including the funding update were strongly advocated for by the Minnesota Environmental Science and Economic Review Board (MESERB), of which we are a member:</p> <ul style="list-style-type: none"> • The new deadline to sign or decline is NOVEMBER 15. If you decide to decline the MOU, MPCA has requested a written letter to be submitted declining the request to participate and explaining any reasons why. • MPCA has been able to obtain funding to help with a portion of the sampling and analysis cost of the Municipal PFAS Monitoring Plan. MESERB requested that MPCA find this funding. Facilities that sign and commit to the terms and conditions of the MOU will have a designated MPCA contractor complete on-site sampling of the first two sampling events. MPCA is still pursuing funding to cover the remaining two samples and will communicate that information if available. • Other changes include clarification of several of the Whereas statements, defined expected actions for the three response thresholds, extension of the overall timeline to complete requested actions, use of a calendar quarter approach for sampling and submitting data, as well as adding an end date for the MOU.
Fiscal Impact:	None at this time. If future sampling and testing costs are not covered by the MPCA they may be expected to cost a few thousand dollars annually.
Alternative/ Variations:	No alternative actions recommended.
Recommendations:	that the Council authorize entering into an MOU with MPCA for a PFAS Monitoring Plan.

Memorandum of Understanding Between your Minnesota District or City and the Minnesota Pollution Control Agency for the Statewide Monitoring of Per- and Polyfluoroalkyl Substances (PFAS)

This Memorandum of Understanding is between your City and the Minnesota Pollution Control Agency (MPCA).

Whereas, PFAS is a known class of environmental contaminants with thousands of unique chemical structures which are persistent in the environment, bioaccumulative, and are in widespread use in industrial, commercial, and household applications;

Whereas, municipal wastewater treatment facilities are a receiver of PFAS and can be a conduit for the discharge of PFAS into the environment;

Whereas, municipal wastewater treatment facilities have regulatory authority over their significant industrial users and generally all users through National Pollutant Discharge Elimination Discharge (NPDES) permits issued to permittees in Minnesota;

Whereas, your permitted wastewater treatment facility has been identified as having at least one significant industrial user;

Whereas, significant industrial users may be a contributing source of PFAS to wastewater treatment facilities;

Whereas, to protect human health and the environment, the MPCA established goals to identify and reduce PFAS in the environment through implementation of its 2022 PFAS Monitoring Plan, that seeks to partner with all sources to reduce releases to the air, water, and land;

Whereas, funding has been appropriated by the Minnesota Legislature to develop tools to assist municipal wastewater treatment facilities in source identification and source reduction of PFAS. This appropriation is specific to these activities and will not be used for sample collection or sample analysis. A contract has been executed between Antea Group and the MPCA where PFAS Source Identification & Reduction tools will be developed. These tools will be available for use in conjunction with the development of PFAS pollutant management plans and;

Whereas, response thresholds will be developed based on data collected from the first two sampling events. The response thresholds will be statistically based, not risked based, to help prioritize source identification and reduction activities. All facilities will be assigned one of three priority categories which will include specific actions for the facilities to complete.

- A. Category one - No further sampling required at this time, unless state or federal funding is obtained. It is strongly encouraged that these facilities complete an inventory of industrial users who may be potential contributors of PFAS. If the MPCA obtains funding to collect and analyze PFAS we reserve the right to collect two additional samples at these facilities.
- B. Category two - Complete an inventory of potential industrial sources of PFAS and start a dialog with those potential sources to initiate source identification and reduction work. Develop, complete, and submit a PFAS Pollutant Management Plan (PFAS PMP) and complete and submit the final two sampling events.

- C. Category three - Complete an inventory of potential industrial sources of PFAS and start a dialog with those potential sources to initiate source identification and reduction work. Develop, complete, and submit a PFAS Pollutant Management Plan (PFAS PMP) and complete and submit the final two sampling events. Based on the industrial user inventory MPCA will work with you to identify further actions to verify PFAS discharges from these potential sources.

Whereas, the MPCA will continue to pursue funding to offset the cost of sample collection and sample analysis. If funding is obtained, an MPCA identified contractor will be used to coordinate and collect samples from designated influent monitoring locations at the wastewater treatment facilities identified in the MPCA PFAS monitoring plan. The collected influent samples will then be sent to an MPCA designated certified laboratory for analysis. Related costs associated with sample collection and analysis will be covered pursuant to the amount of funding obtained and any potential eligibility requirements. The results of the monitoring will be shared with both the monitored wastewater facilities and the MPCA. Data will be submitted via the EQUIS system.

Whereas, MPCA Municipal wastewater contacts for the PFAS Monitoring Plan are:

Jaramie Logelin, jaramie.logelin@state.mn.us, 218-302-6640 or

Sherry Bock, sheryl.bock@state.mn.us, 218-316-3882.

Therefore, Phase I of the 2022 PFAS Monitoring Plan includes a goal that all municipal wastewater treatment facilities, which have delegated pretreatment programs or have identified one or more significant industrial users, will:

- A. Participate in influent wastewater sampling; and
- B. Participate in the identification and understanding of sources of PFAS entering into your wastewater treatment facility; and
- C. If a category two, complete an inventory of potential industrial sources of PFAS and start a dialog with those potential sources to initiate source identification and reduction work. Develop, complete, and submit a PFAS Pollutant Management Plan (PFAS PMP) and complete and submit the final two sampling events; and
- D. If a category three, complete an inventory of potential industrial sources of PFAS and start a dialog with those potential sources to initiate source identification and reduction work. Develop, complete, and submit a PFAS Pollutant Management Plan (PFAS PMP) and complete and submit the final two sampling events. Based on the industrial user inventory, MPCA will work with you to identify further actions to verify PFAS discharges from these potential sources.

In furtherance of these goals, your District or City and MPCA agree to the following actions:

Wastewater Treatment Facility Actions

1. PFAS sampling plan.

- a. By January 1, 2023, develop and submit, for review and approval to the MPCA, a PFAS Sampling Plan specific to the District's or City's PFAS influent monitoring.
 - i. The PFAS Sampling Plan must follow MPCA's updated analytical fact sheet for Per- and Polyfluoroalkyl substances: [Guidance for Per- and Polyfluorinated Alkyl Substance: Analytical \(state.mn.us\)](#).

- ii. The PFAS Sampling Plan must include, but not be limited to, specific sample location, sample collection type, who will be collecting samples (Permittee or contractor), selected lab for analysis and sample analysis method the lab will be using including the reporting limit of each of the PFAS compounds. All samples should be unfiltered and collected at your facility's influent waste stream (WS) station. Each sample shall include at a minimum all PFAS compounds listed in Appendix A. Please note the reporting limits in Appendix A for the six bolded parameters. All other parameters have a goal of under 4 nanograms per liter (ng/L) but will be subject to change upon guidance revisions.
- iii. The PFAS Sampling Plan should be submitted electronically to both Jaramie Logelin and Sherry Bock to their noted emails.

2. Collect Influent Samples.

- a. Collect and submit to the lab round one influent sample by March 31, 2023, in accordance with the completed PFAS sampling plan. By June 30, 2023, submit the first round of influent monitoring data to the MPCA's EQulS database. The monitoring data may be submitted by the District or City or your accredited laboratory.
- b. Collect and submit to the lab round two influent sample by June 30, 2023.
- c. By August 31, 2023, submit the second round of influent monitoring data into MPCA's EQulS database. The monitoring data may be submitted by the District or City or your accredited lab.
- d. Collect and submit to the lab round three influent sample by June 30, 2024.
- e. By September 31, 2024, submit the third round of influent monitoring data to the MPCA's EQulS database. The monitoring data may be submitted by the District or City or your accredited laboratory.
- f. Collect and submit to the lab round four influent sample by September 31, 2024.
- g. By December 31, 2024, submit the results of the fourth round of influent sampling monitoring data into MPCA's EQulS database. The monitoring data may be submitted by the District or City or your accredited lab.

3. Inventory of potential PFAS sources.

- a. By August 31, 2023, start inventorying industrial users that may be potential PFAS contributors to your wastewater collection system
 - i. The initial inventory should identify all industrial users, including but not limited to, all significant industrial users, categorical industrial users, and nonsignificant industrial users based on the NAICS Codes identified in Appendix F of the MPCA's PFAS Monitoring Plan (starting on page 32).
- b. Complete the inventory of potential sources for use in your pollutant management plan by December 31, 2023. Maintain the inventory onsite.

4. PFAS Pollutant Management Plan.

- a. By September 15, 2023, start to develop a PFAS Pollutant Management Plan. The goal will be to identify any non-domestic wastewater sources of PFAS entering your facility and to promote source reduction activities for those sources.
- b. By March 15, 2024, submit the completed PFAS Pollutant Management Plan to the MPCA for review.

5. Implementation of PFAS Pollutant Management Plan.

- a. By 30 days after the submittal of the PFAS Pollutant Management Plan, provide continuing education and information to industrial users and the community on reducing PFAS. Implement the PFAS Pollutant Management Plan and begin implementing follow-up PFAS reduction actions based on MPCA developed response thresholds as identified in MPCA Responsibilities item #5.

6. Continual

- a. Operating and maintaining your wastewater treatment systems to optimize PFAS reduction activities.

MPCA Responsibilities

- 1. By November 1, 2022, establish monitoring and sampling criteria, and a process to capture the data in MPCA’s EQulS database.
- 2. By November 1, 2022, finalize and distribute a final sampling and analysis guide to be used by all facilities.
- 3. Develop and, when available, distribute a Legislative PFAS Source Identification & Reduction Tool Kit to all applicable permittees.
- 4. By September 15, 2023, or within 15 days of substantial submittal of round 1 and 2 monitoring data, develop and communicate response thresholds based on the first two sample results.
- 5. Continue to pursue funding to help cover costs of sample collection and sample analysis. If funding is obtained, it will be dispersed pursuant to any eligibility requirements.

Joint District or City/MPCA Responsibilities

- 1. Collaborate on efforts to work with suppliers, manufacturers, educational institutions, and other interested parties to reduce the use of PFAS in products and procedures where pragmatic alternatives exist.
- 2. Collaborate to develop communication strategies for the public to understand the data and information gained from this joint effort to manage PFAS.

Terms and Conditions

This is a voluntary agreement and can be nullified by either party at any time.

This agreement does not amend, nor shall it be construed as part of the National Pollutant Discharge Elimination System (NPDES) permit for your wastewater treatment facility, however the MPCA expects compliance with provisions within this agreement and reserves the right to utilize MPCA authority under Minn. Stat. § 115.03 to obtain and collect data and information as needed.

This agreement will expire upon the completion of collection and submittal of the final requested sampling data.

Authorized Representatives

The District's or City's Authorized Representative for purposes of administration of the Memorandum of Understanding is:

Marshall Wastewater Treatment Plant

By: Robert Byrnes

Name: Robert Byrnes

Title: Mayor

Date: 10/5/2022

The MPCA's Authorized Representative for purposes of administration of this Memorandum of Understanding is:

**STATE OF MINNESOTA
POLLUTION CONTROL AGENCY**

By: Katrina Kessler

Katrina Kessler, P.E.
Commissioner

Date: October 5, 2022

Appendix A

Minimum list of requested PFAS Compounds

Compound (Acronym) (Source of Compound list and Reporting Limit (RL) goals* found here) *Subject to change upon guidance revision	Aqueous Reporting Limit (RL) Goals (ng/L)	CAS Number
Perfluorobutanoate (PFBA)	under 6	375-22-4
Perfluoropentanoate (PFPeA)		2706-90-3
Perfluorohexanoate (PFHxA)	under 4	307-24-4
Perfluoroheptanoate (PFHpA)		375-85-9
Perfluorooctanoate (PFOA)	under 4	335-67-1
Perfluorononanoate (PFNA)		375-95-1
Perfluorodecanoate (PFDA)		335-76-2
Perfluoroundecanoate (PFUnA)		2058-94-8
Perfluorododecanoate (PFDoA)		307-55-1
Perfluorotridecanoic Acid (PFTTrDA)		72629-94-8
Perfluorotetradecanoic acid (PFTeDA)		376-06-7
Perfluorobutanesulfonate (PFBS)	under 4	375-73-5
Perfluoropentanesulfonate (PFPeS)		2706-91-4
Perfluorohexanesulfonate (PFHxS)	under 4	355-46-4
Perfluoroheptanesulfonate (PFHpS)		375-92-8
Perfluorooctanesulfonate (PFOS)	under 4	1763-23-1
Perfluorononanesulfonate (PFNS)		474511-07-4
Perfluorodecanesulfonate (PFDS)		335-77-3
Perfluorododecanesulfonate (PFDoS)		79780-39-5
4:2 Fluorotelomer sulfonic acid (4:2 FTS)		757124-72-4
6:2 Fluorotelomer sulfonic acid (6:2 FTS)		27619-97-2
8:2 Fluorotelomer sulfonic acid (8:2 FTS)		39108-34-4
N-Methylperfluorooctanesulfonamidoacetic acid (N-MeFOSAA)		2355-31-9
N-Methylperfluorooctanesulfonamidoacetic acid (N-EtFOSAA)		2991-50-6
Perfluorooctane Sulfonamide (PFOSA)		754-91-6
N-Methyl perfluorooctane sulfonamide (N-MeFOSA)		31506-32-8

Compound (Acronym) (Source of Compound list and Reporting Limit (RL) goals* found here) *Subject to change upon guidance revision	Aqueous Reporting Limit (RL) Goals (ng/L)	CAS Number
N-Ethyl perfluorooctane sulfonamide (N-EtFOSA)		4151-50-2
N-Methyl perfluorooctane sulfonamidoethanol (N-MeFOSE)		24448-09-7
N-Ethyl perfluorooctane sulfonamidoethanol (N-EtFOSE)		1691-99-2
Hexafluoropropylene oxide dimer acid (HFPO-DA)		13252-13-6
3H-Perfluoro-3-[(3-methoxy-propoxy) propanoic acid] (ADONA)		919005-14-4
9-Chlorohexadecafluoro-3-oxane-1-sulfonic acid (9Cl-PF3ONS)		756426-58-1
11-chloroeicosafluoro-3-oxaundecane-1-sulfonic acid (11Cl-PF3OUdS)		763051-92-9

Municipal Wastewater PFAS Monitoring and MOU Summary for local decision makers:

- Per- and polyfluoroalkyl substances (PFAS) are a family of nearly 5,000 chemicals which have been widely used in industrial, commercial, and residential applications, are resistant to breakdown, and are found virtually everywhere in our environment.
- At concentrations which vary by specific chemical, PFAS can be toxic, causing adverse health effects in humans, fish, and wildlife.
- In February of 2021, the MPCA released a PFAS Blueprint for addressing PFAS statewide. This was followed by a PFAS Monitoring Plan (March 2022) which identifies how the MPCA will collect PFAS monitoring data from all major regulatory program areas.
- Wastewater treatment plants (WWTPs) are a receiver of PFAS and can be a conduit for the discharge of PFAS into the environment. PFAS can be present in wastewater which flows to WWTPs and is not treated by conventional treatment technologies. PFAS treatment at the wastewater treatment facility is not economically feasible at this point, so the MPCA is focusing on source identification and source reduction.
- In an effort to collaborate with the WWTPs the MPCA has asked that the monitoring be completed outside the City's wastewater permit, through the use of the MOU.
- The MPCA is requesting approximately 90 municipal WWTPs, which have identified significant industrial users, to participate in phase 1 of the PFAS Monitoring Plan. By signing a Memorandum of Understanding (MOU), these facilities agree to the following:
 1. Submit a PFAS Sampling Plan
 2. Collect four quarterly influent samples
 3. Inventory potential sources, develop a PFAS Pollutant Management Plan, and work with industrial users and other users to reduce PFAS in wastewater influent base on a defined response threshold.
- The MPCA has secured funding to cover the costs of sample collection and analysis for the first two influent samples for facilities who sign the MOU. The MPCA will continue to pursue funding in an effort to potentially cover some or all of the costs of collecting and analyzing the last two influent samples.
- The goal of this monitoring is to:
 1. Evaluate PFAS concentrations discharged to WWTPs,
 2. Identify sources of PFAS,
 3. Begin to make progress reducing PFAS discharged to WWTPs, and
 4. To inform future monitoring and regulatory decisions in future phases of the PFAS monitoring plan in an effort to reduce PFAS discharged to the environment.

**CITY OF MARSHALL
AGENDA ITEM REPORT**

Presenter:	Jim Marshall, Director of Public Safety
Meeting Date:	Tuesday, October 25, 2022
Category:	CONSENT AGENDA
Type:	ACTION
Subject:	Contract with State of Minnesota and the City of Marshall for HAZMAT Services to Southwest Minnesota
Background Information:	<p>For twenty years the City of Marshall has been committed to a professional and technical services contract with the State of Minnesota to provide regional HAZMAT response to a fourteen-county area through the Southwest Minnesota Chemical Assessment Team. In October of 2022 the current contract ended, and the Marshall Fire Department was asked to submit a proposal to continue the services through June 30th, 2024.</p> <p>On October 17th, 2022, the State Fire Marshal’s Office awarded the attached contract to the Marshall Fire Department. The total dollar amount of the contract is for \$100,000. The duties, amounts and payments are similar to past contracts.</p> <p>Additional equipment, capital items and funding may be made available to the City of Marshall throughout the term of the contract.</p>
Fiscal Impact:	No matching funds required - \$100,000 awarded to the City of Marshall
Alternative/ Variations:	None
Recommendations:	Consider entering into an agreement with the State of Minnesota for the Marshall Fire Department to provide HAZMAT Response to Southwest Minnesota.



State of Minnesota Contract

SWIFT Contract No.:

This Contract is between the **State of Minnesota**, acting through its Commissioner of Public Safety on behalf of the State Fire Marshal division (“State”), and **City of Marshall**, acting on behalf of its Fire Department, whose designated business address is 201 East Saratoga Street, Marshall, MN 53258 (“Contractor”). The State and Contractor may be referred to jointly as “Parties.”

Recitals

1. State issued a solicitation identified as SWIFT Event 2000013294 on September 6, 2022, for hazardous materials (HAZMAT) response teams to assist local authorities by providing technical advice to local incident commanders and recommending mitigation actions necessary to protect life, property, and the environment (“Solicitation”); and
2. Contractor provided a response to the Solicitation indicating its interest in and ability to provide the services requested in the Solicitation; and
3. Subsequent to an evaluation in accordance with the terms of the Solicitation and negotiation, the Parties desire to enter into a contract.

Accordingly, the Parties agree as follows:

Contract

1. Term of Contract

- 1.1 Effective Date. **November 1, 2022**, or the date the State obtains all required signatures under Minn. Stat. § 16C.05, subd. 2, whichever is later. The Contractor must not begin work under this Contract until this Contract is fully executed and the Contractor has been notified by the State’s Authorized Representative to begin work.
- 1.2 Expiration Date. **June 30, 2024**, or until all obligations have been satisfactorily fulfilled, whichever occurs first.

2. Contractor’s Duties

The Contractor shall perform all duties described in this Contract to the satisfaction of the State.

The Contractor, who is not a State employee, shall:

- (a) Respond to hazardous material incidents occurring in the Contractor’s normal geographic area (*see Appendix C*), and, when requested by the State, the Contractor’s primary response area (*see Appendix A*) and secondary response area (*Appendix B*).
- (b) Respond to any response area in the State of Minnesota (*see Appendix B*) when directed to do so by the Commissioner (*Minnesota Rules Chapter 7514.0900, subpart 1*).
- (c) Coordinate on-scene emergency response operations of the Contractor’s Team with local, state and federal agencies, Indian tribes, and private response organizations through the Minnesota Incident Management System (*Minnesota Rules Chapter 7514.1800, subpart 1*).

- (d) Ensure Contractor's Team members are in compliance with the initial, continuing education, and team training requirements (*Minnesota Rules Chapter 7514.0600, subparts 1 to 4*); and annually certify such compliance to the Commissioner (*Minnesota Rules Chapter 7514.0600, subpart 6*).
- (e) Ensure Team members are in compliance with medical requirements (*Minnesota Rules Chapter 7514.0600, subpart 7*); and annually certify such compliance to the Commissioner (*Minnesota Rules Chapter 7514.0600, subpart 7*).
- (f) Deploy Contractor's Team personnel and equipment to hazardous materials incident(s) within an average of fifteen (15) minutes from the time a decision is made to dispatch the Team (*Minnesota Rules, Chapter 7514.0500*). For purposes of this clause, the decision to dispatch the Team will be considered made at the time the Contractor's point of contact as identified in *Appendix D* is notified by the State.
- (g) Ensure compliance with all other employer requirements established in *Minnesota Rules Chapter 7514.0600*.
- (h) Conduct a formal evaluation of the hazardous materials emergency response to an incident within thirty (30) days after termination of the Contractor's Team's response (*Minnesota Rules Chapter 7514.1300*).
- (i) Submit a detailed report of the Team's response to an incident as required by *Minnesota Rules Chapter 7514.0900, subpart 7*; and as required by *Minnesota Rules Chapter 7514.1700, subparts 1 and 3*; and take appropriate measures to identify to the State the responsible person of each incident, including responsible person's social security number or federal tax identification number.
- (j) Designate one (1) primary and one (1) alternate representative to the State's Hazardous Materials Emergency Response Team Program Advisory Committee (*see Appendix F*); require one or both representatives to attend all meetings convened by the Committee; and empower each representative to make recommendations to the Committee on behalf of the Contractor.
- (k) Designate one (1) primary and one (1) alternate representative (*see Appendix F*) and require each representative to train in applying operating guidelines and other administrative procedures established and identified by the State's Hazardous Materials Emergency Response Team Program (*Minnesota Rules Chapter 7514.0700, subpart 2*); and require one or both representatives to instruct other Team members.
- (l) Maintain and store emergency response vehicle(s) and equipment, whether loaned to the Contractor by the State or owned by the Contractor, in proper working order and ready for response at all times, except as may be necessary for the performance of routine or necessary maintenance, repairs, or replacement. Contractor must immediately notify the State whenever Contractor is not available for emergency response as a result of such circumstances.
- (m) Submit claims for recoverable costs to the Commissioner as required by *Minnesota Rules Chapter 7514.1700, subparts 1 and 3*; and take all appropriate measures to identify to the State the responsible person of each incident, including responsible person's social security number or federal tax identification number.
- (n) Maintain the required composition of a Hazardous Materials Emergency Response Team, including the availability for immediate response of three (3) members minimum certified to the levels of hazardous materials technician response and training. The State recommends maintaining a level of five (5) members for immediate response; and the Contractor agrees to obtain approval from the State's Authorized Representative or his designee prior to deploying more than five (5) team members to an incident.
- (o) Respond to incidents and assist local authorities at the scene of a hazardous materials incidents by providing reasonable mitigation; and recommend to the local incident manager the best means of controlling the hazard after consideration of life safety concerns, environmental effects, exposure hazards, quantity and type of hazardous material, availability of resources, or other relevant factors.

- (p) Asses an incident, develop and recommend mitigation strategies, and assist with response operations (Minnesota Rules Chapter 7514.0900, subpart 4).

The Contractor shall not subcontract any work, duties or tasks pursuant to this Contract.

3. Representations and Warranties

- 3.1 Under Minn. Stat. §§ 15.061 and 16C.03, subd. 3, the State is empowered to engage such assistance as deemed necessary.
- 3.2 Contractor warrants that it is duly qualified and shall perform its obligations under this Contract in accordance with the commercially reasonable standards of care, skill, and diligence in Contractor's industry, trade, or profession, and in accordance with the specifications set forth in this Contract, to the satisfaction of the State.
- 3.3 Contractor warrants that it possesses the legal authority to enter into this Contract and that it has taken all actions required by its procedures, by-laws, and applicable laws to exercise that authority, and to lawfully authorize its undersigned signatory to execute this Contract, or any part thereof, and to bind Contractor to its terms.

4. Time

The Contractor must comply with all the time requirements described in this Contract. In the performance of this Contract, time is of the essence.

5. Payment

5.1 Consideration. The State will pay for all services performed by the Contractor under this Contract as follows:

- (a) **Compensation.** The State will pay the Contractor up to but not exceeding **Forty Thousand and 00/100 Dollars (\$40,000.00)** for the period commencing November 1, 2022, and ending June 30, 2023, and **Sixty Thousand and 00/100 Dollars (\$60,000.00)** for the period commencing July 1, 2023, and ending June 30, 2024. The Contractor will be paid for expenses for the following costs:
- 1) Capital equipment – Cost of capital equipment including vehicles.
 - 2) Training – Cost of training team personnel (excluding exercise training).
 - 3) Medical examinations – Cost of annual medical examinations for team personnel.
 - 4) Consumable supplies – Cost of consumable supplies.
 - 5) Administration – Cost of program administration.
 - 6) Maintenance – Cost of equipment maintenance.
- (b) Contractor may deviate from its budget corresponding to the six categories identified in Clause 5.1(a), increasing and decreasing amounts between categories as needed with the exception of Category 5, Administration. The State and Contractor mutually agree Administration costs shall not be increased more than 20% without prior written approval from the State's Authorized Representative.
- (c) **Total Obligation.** The total obligation of the State for all compensation to the Contractor corresponding to Clause 5.1(a) shall not exceed **One Hundred Thousand and 00/100 Dollars (\$100,000.00)**.
- (d) **Emergency Response Reimbursement.** In addition to the Compensation identified in Clause 5.1(a) and Clause 5.1(c), the State will reimburse the Contractor for reasonable and necessary expenses corresponding to and directly associated with the following costs incurred during an actual emergency response. Reimbursement costs corresponding to this section shall not exceed **Five Thousand and 00/100 Dollars (\$5,000.00)** for any single response unless authorized by the State's Authorized Representative.

- 1) **Hazmat Team Personnel Costs**
An hourly rate per person, including wages and fringe benefits, for two (2) hours minimum per person, up to five (5) persons [See Clause 2(n) above]. Hourly rates will be determined by and in accordance with the Contractor's collective bargaining agreement(s) corresponding to personnel.
- 2) **Additional Wage Costs for Local Callback Personnel**
An hourly rate per person, including wages and fringe benefits, for two (2) hours minimum per person, up to five (5) persons for HAZMAT team. Hourly rates will be determined by and in accordance with the Contractor's collective bargaining agreement(s) corresponding to personnel.
- 3) **Vehicle Operating Costs**
 - a) Hazardous Materials Response Teams shall be reimbursed up to \$150.00 per hour for operational costs associated with State-supplied Hazardous Materials Emergency Response apparatus.
 - b) Any additional Hazardous Materials Response Team support apparatus shall be reimbursed up to \$100.00 per hour which must be approved prior to use by the State Fire Marshal's State Teams Coordinator or Supervisor.
- 4) **Cost of Consumable Supplies Used**
Cost for consumable supplies used shall not exceed the actual costs incurred; and Contractor must submit an itemized invoice for actual costs to be reimbursed.
- 5) **Costs of Repair or Replacement of Damaged or Destroyed Equipment**
Contractor must submit an itemized invoice for actual costs incurred. If cost is estimated to exceed \$500.00, Contractor shall consult with the State's Authorized Representative to determine if the State will require competitive bids or quotes prior to the repair or replacement of equipment. If the State requires a competitive solicitation, Contractor must comply with the applicable municipal bidding laws.
- 6) **Communication Costs, including Long Distance and Cellular Telephone Charges**
Eligible costs are defined as cellular/mobile and land line telephone costs for voice, data, and facsimile transmissions. Contractor must submit an itemized invoice for actual costs incurred.
- 7) **Administrative Costs Directly Resulting from the Emergency Response**
Up to \$500.00 per incident based on actual costs incurred. Contractor may request additional administrative cost reimbursement based on an itemized invoice for actual costs incurred when extraordinary circumstances resulting from a specific State authorized emergency response are documented.
- 8) **Costs Incurred in the Use of Special Equipment (Minnesota Rules Chapter 7514.1200)**
Costs for this item shall not exceed the actual costs incurred; and Contractor must submit an itemized invoice for actual costs to be reimbursed.
- 9) **Costs Associated with Providing Support to Cleanup Operations (Minnesota Rules Chapter 7514.0900, subpart 5)**
Costs for this item shall not exceed the actual costs incurred; and Contractor must submit an itemized invoice for actual costs to be reimbursed.
- 10) **Costs Associated with Providing Standby Technical Assistance (Minnesota Rules Chapter 7514.1600, subpart 4)**
Costs for this item shall not exceed the actual costs incurred; and Contractor must submit an itemized invoice for actual costs to be reimbursed.
- 11) **Other Direct Costs Incurred by the Contractor as a Result of the Emergency Response**
Costs for this item shall not exceed the actual costs incurred; and Contractor must submit

an itemized invoice for actual costs to be reimbursed.

5.2 Payment.

- (a) **Invoices.** The State will promptly pay the Contractor after the Contractor presents an itemized invoice for the services actually performed and the State's Authorized Representative accepts the invoiced services. Invoices must be submitted timely and according to the following schedule:
 - 1) **Contractor Compensation [Clauses 5.1(a) and 5.1(b)].** Contractor shall submit a completed Contractor Compensation Packet at least once every three months but not more frequently than once per month for reimbursement of costs identified in Clauses 5.1(a) and 5.1(b). Contractor shall submit a final invoice for the period commencing November 1, 2022, and ending June 20, 2023, no later than July 31, 2023. Contractor shall submit a final invoice for the period commencing July 1, 2023, and ending June 30, 2024, no later than July 31, 2024. The State will process properly completed Reimbursement Packets for compensation within thirty (30) days of receipt.
 - 2) **Emergency Response Reimbursement [Clause 5.1(d)].** Contractor shall submit a reimbursement claim form identifying reasonable and necessary expenses incurred during an actual emergency response, such claim form to be submitted to State no later than forty-five (45) days after the end of the response. The claim for reimbursement must be made on forms provided by the State and must provide sufficient detail corresponding to each category identified in Clause 5.1(d). The State will process properly completed claim forms for reimbursement within thirty (30) days of receipt.

6. **Authorized Representatives**

State's Authorized Representative.

The State's Authorized Representative is the individual below, or his successor, and has the responsibility to monitor the Contractor's performance.

Name: James G. Smith, State Fire Marshal
 Address: Department of Public Safety; State Fire Marshal Division
 445 Minnesota Street, Suite 145
 Saint Paul, MN 55101
 Telephone: 651.201.7402
 Email Address: james.g.smith@state.mn.us

Contractor's Authorized Representative.

The Contractor's Authorized Representative is the individual below, or his successor. If the Contractor's Authorized Representative changes at any time during this Contract, the Contractor must notify the State in writing/email within ten (10) business days.

Name: Quentin Brunsvold, Fire Chief
 Address: Marshall Fire Department
 201 East Saratoga Street
 Marshall, MN 53258
 Telephone: 507-530-7623
 Email Address: quentin.brunsvold@ci.marshall.mn.us

7. **Exhibits and Appendices**

The following Exhibits are attached and incorporated into this Contract. In the event of a conflict between the terms of this Contract and its Exhibits, or between Exhibits, the order of precedence is first the Contract, and then in the following order:

Exhibit A: Contract Terms

- Exhibit B: Insurance Terms and Requirements
- Appendix A: Primary Response Area
- Appendix B: Secondary Response Area
- Appendix C: Normal Geographic Jurisdiction
- Appendix D: Point-of-Contact for Team Dispatching
- Appendix E: Designees of State's Authorized Representative
- Appendix F: Primary and Alternate Representatives to the HAZMAT Response Team

1. State Encumbrance Verification
Individual certifies that funds have been encumbered as required by Minn. Stat. §§ 16A.15 and 16C.05

Print name: _____

Signature: _____

Title: _____ Date: _____

SWIFT PO Number: _____

3. State: Department of Public Safety; State Fire Marshal Division
With delegated authority

Print name: _____

Signature: _____

Title: _____ Date: _____

2. Contractor: City of Marshall
The Contractor certifies that the appropriate person has executed this Contract on behalf of the Contractor as required by applicable articles, bylaws, resolutions, or ordinances.

Print name: _____

Signature: _____

Title: _____ Date: _____

4. Commissioner of Administration
As delegated to the Office of State Procurement

Print name: _____

Signature: _____

Title: _____ Date: _____

Exhibit A: Contract Terms

1. Prompt Payment and Invoicing

Prompt Payment. The State will pay the Contractor pursuant to Minn. Stat. § 16A.124 which requires payment within 30 days following receipt of an undisputed invoice or service, whichever is later. Terms requesting payment in less than 30 days will be changed to read "Net 30 days." The payment will only be made for services actually performed that have been accepted by the State's Authorized Representative, and that meet all terms, conditions, and specifications of the Contract and the solicitation document.

2. Assignment, Amendments, Waiver, and Contract Complete

- 2.1 Assignment. The Contractor may neither assign nor transfer any rights or obligations under this Contract without the prior consent of the State and a fully executed assignment agreement, executed and approved by the authorized parties or their successors.
- 2.2 Amendments. Any amendment to this Contract must be in writing and will not be effective until it has been executed and approved by the authorized parties or their successors.
- 2.3 Waiver. If the State fails to enforce any provision of this Contract, that failure does not waive the provision or its right to enforce it.
- 2.4 Contract Complete. This Contract contains all negotiations and agreements between the State and the Contractor. No other understanding regarding this Contract, whether written or oral, may be used to bind either party.

3. Termination

- 3.1 Termination for Convenience. The State or Commissioner of Administration may cancel this Contract at any time, with or without cause, upon 30 days' written notice to the Contractor. Upon termination for convenience, the Contractor will be entitled to payment, determined on a pro rata basis, for services satisfactorily performed.
- 3.2 Termination for Breach. The State may terminate this Contract, with cause, upon 30 days' written notice to Contractor of the alleged breach and opportunity to cure. If after 30 days, the alleged breach has not been remedied, the State may immediately terminate the Contract.
- 3.3 Termination for Insufficient Funding. The State may immediately terminate this Contract if it does not obtain funding from the Minnesota Legislature, or other funding source, or if funding cannot be continued at a level sufficient to allow for payment of the services addressed within this Contract. Termination must be by written notice to the Contractor. The State is not obligated to pay for any services that are provided after notice and effective date of termination. However, the Contractor will be entitled to payment, determined on a pro rata basis, for services satisfactorily performed to the extent that dedicated funds are available. The State will not be assessed any penalty if the Contract is terminated because of the decision of the Minnesota Legislature, or other funding source, not to appropriate funds. The State must provide the Contractor notice of the lack of funding. This notice will be provided within a reasonable time of the State's receiving notice.

4. Force Majeure

Neither party shall be responsible to the other or considered in default of its obligations within this Contract to the extent that performance of any such obligations is prevented or delayed by acts of God, war, riot, disruption of government, or other catastrophes beyond the reasonable control of the party unless the act or occurrence could have been reasonably foreseen and reasonable action could have been taken to prevent the delay or failure to perform. A party relying on this provision to excuse performance must provide the other party prompt written notice of the inability to perform and take all necessary steps to bring about performance as soon as practicable.

5. Indemnification

5.1 In the performance of this Contract, the Indemnifying Party must indemnify, save, and hold harmless the State, its agents, and employees, from any claims or causes of action, including attorney's fees incurred by the State, to the extent caused by Indemnifying Party's:

- Intentional, willful, or negligent acts or omissions; or
- Actions that give rise to strict liability; or
- Breach of contract or warranty.

The Indemnifying Party is defined to include the Contractor, Contractor's reseller, any third party that has a business relationship with the Contractor, or Contractor's agents or employees, and to the fullest extent permitted by law. The indemnification obligations of this section do not apply in the event the claim or cause of action is the result of the State's sole negligence. This clause will not be construed to bar any legal remedies the Indemnifying Party may have for the State's failure to fulfill its obligation under this Contract.

5.2 Nothing within this Contract, whether express or implied, shall be deemed to create an obligation on the part of the State to indemnify, defend, hold harmless or release the Indemnifying Party. This shall extend to all agreements related to the subject matter of this Contract, and to all terms subsequently added, without regard to order of precedence.

6. Governing Law, Jurisdiction, and Venue

Minnesota law, without regard to its choice-of-law provisions, governs this Contract. Venue for all legal proceedings out of this Contract, or its breach, must be in the appropriate state or federal court with competent jurisdiction in Ramsey County, Minnesota.

7. Foreign Outsourcing of Work Prohibited

All services under this contract shall be performed within the borders of the United States. All storage and processing of information shall be performed within the borders of the United States. This provision also applies to work performed by all subcontractors.

8. Data Disclosure

Under Minn. Stat. § 270C.65, subd. 3, and other applicable law, the Contractor consents to disclosure of its social security number, federal employer tax identification number, and Minnesota tax identification number, already provided to the State, to federal and state agencies, and state personnel involved in the payment of state obligations. These identification numbers may be used in the enforcement of federal and state laws which could result in action requiring the Contractor to file state tax returns, pay delinquent state tax liabilities, if any, or pay other state liabilities.

9. Government Data Practices

The Contractor and State must comply with the Minnesota Government Data Practices Act, Minn. Stat. Ch. 13, as it applies to all data provided by the State under this Contract, and as it applies to all data created, collected, received, stored, used, maintained, or disseminated by the Contractor under this Contract. The civil remedies of Minn. Stat. § 13.08 apply to the release of the data governed by the Minnesota Government Practices Act, Minn. Stat. Ch. 13, by either the Contractor or the State.

If the Contractor receives a request to release the data referred to in this clause, the Contractor must immediately notify and consult with the State's Authorized Representative as to how the Contractor should respond to the request. The Contractor's response to the request shall comply with applicable law.

10. Intellectual Property Rights

10.1 Definitions. For the purpose of this Section, the following words and phrases have the assigned definitions:

- 10.1.1 "Documents" are the originals of any databases, computer programs, reports, notes, studies, photographs, negatives, designs, drawings, specifications, materials, tapes, disks, or other materials,

whether in tangible or electronic forms, prepared by the Contractor, its employees, agents, or subcontractors, in the performance of this Contract.

10.1.2 “Pre-Existing Intellectual Property” means intellectual property developed prior to or outside the scope of this Contract, and any derivatives of that intellectual property.

10.1.3 “Works” means all inventions, improvements, discoveries (whether or not patentable), databases, computer programs, reports, notes, studies, photographs, negatives, designs, drawings, specifications, materials, tapes, and disks conceived, reduced to practice, created or originated by the Contractor, its employees, agents, and subcontractors, either individually or jointly with others in the performance of this Contract. “Works” includes Documents.

10.2 Ownership. The State owns all rights, title, and interest in all of the intellectual property rights, including copyrights, patents, trade secrets, trademarks, and service marks in the Works and Documents *created and paid for under this Contract*. The Documents shall be the exclusive property of the State and all such Documents must be immediately returned to the State by the Contractor upon completion or cancellation of this Contract. To the extent possible, those Works eligible for copyright protection under the United States Copyright Act will be deemed to be “works made for hire.” The Contractor assigns all right, title, and interest it may have in the Works and the Documents to the State. The Contractor must, at the request of the State, execute all papers and perform all other acts necessary to transfer or record the State’s ownership interest in the Works and Documents.

10.3 Pre-existing Intellectual Property. Each Party shall retain ownership of its respective Pre-Existing Intellectual Property. The Contractor grants the State a perpetual, irrevocable, non-exclusive, royalty free license for Contractor’s Pre-Existing Intellectual Property that are incorporated in the products, materials, equipment, deliverables, or services that are purchased through the Contract.

10.4 Obligations.

10.4.1 Notification. Whenever any invention, improvement, or discovery (whether or not patentable) is made or conceived for the first time or actually or constructively reduced to practice by the Contractor, including its employees and subcontractors, in the performance of this Contract, the Contractor will immediately give the State’s Authorized Representative written notice thereof, and must promptly furnish the State’s Authorized Representative with complete information and/or disclosure thereon.

10.4.2 Representation. The Contractor must perform all acts, and take all steps necessary to ensure that all intellectual property rights in the Works and Documents are the sole property of the State, and that neither Contractor nor its employees, agents, or subcontractors retain any interest in and to the Works and Documents. The Contractor represents and warrants that the Works and Documents do not and will not infringe upon any intellectual property rights of other persons or entities.

10.4.3 Indemnification. Notwithstanding any other indemnification obligations addressed within this Contract, the Contractor will indemnify; defend, to the extent permitted by the Attorney General; and hold harmless the State, at the Contractor’s expense, from any action or claim brought against the State to the extent that it is based on a claim that all or part of the Works or Documents infringe upon the intellectual property rights of others. The Contractor will be responsible for payment of any and all such claims, demands, obligations, liabilities, costs, and damages, including but not limited to, attorney fees. If such a claim or action arises, or in the Contractor’s or the State’s opinion is likely to arise, the Contractor must, at the State’s discretion, either procure for the State the right or license to use the intellectual property rights at issue or replace or modify the allegedly infringing works or documents as necessary and appropriate to obviate the infringement claim. This remedy of the State will be in addition to and not exclusive of other remedies provided by law.

11. Copyright

The Contractor shall save and hold harmless the State of Minnesota, its officers, agents, servants and employees, from liability of any kind or nature, arising from the use of any copyrighted or noncopyrighted compositions, secret process, patented or nonpatented invention, article or appliance furnished or used in the performance of the Contract.

12. Contractor's Documents

Any licensing and maintenance agreement, or any order-specific agreement or document, including any pre-installation, linked or "click through" agreement that is allowed by, referenced within or incorporated within the Contract whenever the Contract is used for a State procurement, whether directly by the Contractor or through a Contractor's agent, subcontractor or reseller, is agreed to only to the extent the terms within any such agreement or document do not conflict with the Contract or applicable Minnesota or Federal law, and only to the extent that the terms do not modify, diminish or derogate the terms of the Contract or create an additional financial obligation to the State. Any such agreement or document must not be construed to deprive the State of its sovereign immunity, or of any legal requirements, prohibitions, protections, exclusions or limitations of liability applicable to this Contract or afforded to the State by Minnesota law. A State employee's decision to choose "accept" or an equivalent option associated with a "click-through" agreement does not constitute the State's concurrence or acceptance of terms, if such terms are in conflict with this section.

13. State Audits

Under Minn. Stat. § 16C.05, subd. 5, the Contractor's books, records, documents, and accounting procedures and practices relevant to this Contract are subject to examination by the State, the State Auditor, or Legislative Auditor, as appropriate, for a minimum of six (6) years from the expiration or termination of this Contract.

14. Publicity and Endorsement

14.1 Publicity. Any publicity regarding the subject matter of this Contract must identify the State as the sponsoring agency and must not be released without prior written approval from the State's Authorized Representative. For purposes of this provision, publicity includes notices, informational pamphlets, press releases, information posted on corporate or other websites, research, reports, signs, and similar public notices prepared by or for the Contractor individually or jointly with others, or any subcontractors, with respect to the program, publications, or services provided resulting from this Contract.

14.2 Endorsement. The Contractor must not claim that the State endorses its products or services.

15. Debarment by State, its Departments, Commissions, Agencies, or Political Subdivisions

Contractor certifies that neither it nor its principals is presently debarred or suspended by the Federal government, the State, or any of the State's departments, commissions, agencies, or political subdivisions. Contractor's certification is a material representation upon which the Contract award was based. Contractor shall provide immediate written notice to the State's Authorized Representative if at any time it learns that this certification was erroneous when submitted or becomes erroneous by reason of changed circumstances.

16. Contingency Fees Prohibited

Pursuant to Minn. Stat. § 10A.06, no person may act as or employ a lobbyist for compensation that is dependent upon the result or outcome of any legislation or administrative action.

17. Certification of Nondiscrimination (in accordance with Minn. Stat. § 16C.053)

If the value of this Contract, including all extensions, is \$50,000 or more, Contractor certifies it does not engage in and has no present plans to engage in discrimination against Israel, or against persons or entities doing business in Israel, when making decisions related to the operation of the vendor's business. For purposes of this section, "discrimination" includes but is not limited to engaging in refusals to deal, terminating business activities, or other actions that are intended to limit commercial relations with Israel, or persons or entities doing business in Israel, when such actions are taken in a manner that in any way discriminates on the basis of nationality or national origin and is not based on a valid business reason.

18. Non-discrimination (in accordance with Minn. Stat. § 181.59)

The Contractor will comply with the provisions of Minn. Stat. § 181.59.

19. E-Verify Certification (in accordance with Minn. Stat. § 16C.075)

For services valued in excess of \$50,000, Contractor certifies that as of the date of services performed on behalf of the State, Contractor and all its subcontractors will have implemented or be in the process of implementing the federal E-Verify Program for all newly hired employees in the United States who will perform work on behalf of the State. Contractor is responsible for collecting all subcontractor certifications and may do so utilizing the E-Verify Subcontractor Certification Form available at <http://www.mmd.admin.state.mn.us/doc/EverifySubCertForm.doc>. All subcontractor certifications must be kept on file with Contractor and made available to the State upon request.

20. Affirmative Action Requirements

The State intends to carry out its responsibility for requiring affirmative action by its contractors.

- 20.1 Covered Contracts and Contractors. If the Contract exceeds \$100,000 and the Contractor employed more than 40 full-time employees on a single working day during the previous 12 months in Minnesota or in the state where it has its principal place of business, then the Contractor must comply with the requirements of Minn. Stat. § 363A.36 and Minn. R. 5000.3400-5000.3600.
- 20.2 General. Minn. R. 5000.3400-5000.3600 implements Minn. Stat. § 363A.36. These rules include, but are not limited to, criteria for contents, approval, and implementation of affirmative action plans; procedures for issuing certificates of compliance and criteria for determining a contractor’s compliance status; procedures for addressing deficiencies, sanctions, and notice and hearing; annual compliance reports; procedures for compliance review; and contract consequences for non-compliance. The specific criteria for approval or rejection of an affirmative action plan are contained in various provisions of Minn. R. 5000.3400-5000.3600 including, but not limited to, Minn. R. 5000.3420-5000.3500 and 5000.3552-5000.3559.
- 20.3 Disabled Workers. The Contractor must comply with the following affirmative action requirements for disabled workers.

AFFIRMATIVE ACTION FOR DISABLED WORKERS

- 20.3.1 The Contractor must not discriminate against any employee or applicant for employment because of physical or mental disability in regard to any position for which the employee or applicant for employment is qualified. The Contractor agrees to take affirmative action to employ, advance in employment, and otherwise treat qualified disabled persons without discrimination based upon their physical or mental disability in all employment practices such as the following: employment, upgrading, demotion or transfer, recruitment, advertising, layoff or termination, rates of pay or other forms of compensation, and selection for training, including apprenticeship.
- 20.3.2 The Contractor agrees to comply with the rules and relevant orders of the Minnesota Department of Human Rights issued pursuant to the Minnesota Human Rights Act.
- 20.3.3 In the event of the Contractor's noncompliance with the requirements of this clause, actions for noncompliance may be taken in accordance with Minn. Stat. § 363A.36, and the rules and relevant orders of the Minnesota Department of Human Rights issued pursuant to the Minnesota Human Rights Act.
- 20.3.4 The Contractor agrees to post in conspicuous places, available to employees and applicants for employment, notices in a form to be prescribed by the Commissioner. Such notices must state the Contractor's obligation under the law to take affirmative action to employ and advance in employment qualified disabled employees and applicants for employment, and the rights of applicants and employees.
- 20.3.5 The Contractor must notify each labor union or representative of workers with which it has a collective bargaining agreement or other contract understanding, that the Contractor is bound by the terms of Minn. Stat. § 363A.36 of the Minnesota Human Rights Act and is committed to take affirmative action to employ and advance in employment physically and mentally disabled persons.
- 20.4 Consequences. The consequences for the Contractor’s failure to implement its affirmative action plan or make a good faith effort to do so include, but are not limited to, suspension or revocation of a certificate of

compliance by the Commissioner, refusal by the Commissioner to approve subsequent plans, and termination of all or part of this Contract by the Commissioner or the State.

20.5 Certification. The Contractor hereby certifies that it is in compliance with the requirements of Minn. Stat. § 363A.36 and Minn. R. 5000.3400-5000.3600 and is aware of the consequences for noncompliance.

21. Equal Pay Certification

If required by Minn. Stat. §363A.44, the Contractor must have a current Equal Pay Certificate prior to Contract execution. If Contractor's Equal Pay Certificate expires during the term of this Contract, Contractor must promptly re-apply for an Equal Pay Certificate with the Minnesota Department of Human Rights and notify the State's Authorized Representative once the Contractor has received the renewed Equal Pay Certificate. If Contractor claims to be exempt, the State may require Contractor to verify its exempt status.

22. Other Provisions

- 22.1 Primary Response Area. The Contractor's primary response area is described in Appendix A.
- 22.2 Secondary Response Area. The Contractor's secondary response area is described in Appendix B.
- 22.3 Contractor's Geographic Jurisdiction. The Contractor's normal geographic jurisdiction is described in Appendix C.
- 22.4 Point of Contact for Team Dispatching. The Contractor agrees to maintain a single point-of-contact who will be used by the State to dispatch Contractor. The Contractor's single point-of-contact is identified in Appendix D.
- 22.5 Designees of the State's Authorized Representative. Appendix E identifies the designees of the State's Authorized Representative and their delegated authority to act on his behalf.
- 22.6 Contractor's Primary and Alternate Representatives. The Contractor's primary and alternate representatives are identified in Appendix F.
- 22.7 State Owned and Provided Equipment. When applicable, the State agrees to loan or provide the Contractor the equipment required for Contractor to execute its duties, responsibilities and tasks pursuant to this Contract in accordance with the following terms and conditions:
 - 22.7.1 Contractor may use and maintain possession of the equipment (see clause 22.9).
 - 22.7.2 The State will retain title and legal ownership of all loaned, capitalized equipment loaned to the Contractor and will provide for its replacement (see clause 22.9).
 - 22.7.3 The State will administer any manufacturer's warranty claims of state-owned equipment that may result during Contractor's use of the equipment.
 - 22.7.4 The State will, upon request of Contractor, train at least one person designated by Contractor in the proper handling, use and maintenance of the equipment used pursuant to this Contract. The State shall provide the training to Contractor's personnel without cost, other than travel and related expenses which shall be paid by the Contractor. The Contractor will bear the cost of any travel and related expenses incurred the Contractor's employee(s) attending training. The Contractor's team member trained by the State in the proper use, handling and maintenance of the equipment will provide training to Contractor's team members and other appropriate personnel as designated by the Contractor.
 - 22.7.5 The State will, upon request of Contractor, provide Contractor with technical assistance as needed regarding the proper handling, use and maintenance of the equipment.
 - 22.7.6 The Contractor will maintain all necessary inventory control records on the equipment used pursuant to this Contract.
 - 22.7.7 The Contractor will make the equipment available to personnel authorized by the State when required for inventory, inspection or auditing purposes.
 - 22.7.8 The Contractor will keep and maintain the equipment in proper operating condition.
 - 22.7.9 The Contractor will re-supply all disposable, expired and consumable components originally provided by the State, and will supply and other needed disposable and consumable components not provided by State, at Contractor's expense.

- 22.7.10 The Contractor will be responsible for the cost of repairing or replacing equipment that has been lost, or as determined by the State, damaged due to abuse, misuse or other cause outside normal wear and tear, incurred in the routine proper use. The State will determine whether the equipment will be repaired or replaced.
- 22.7.11 The Contractor will be responsible for the cost of routine maintenance and repair according to the manufacturer's recommendations.
- 22.7.12 The Contractor will return capitalized equipment purchased by the State to the State upon termination, expiration, or cancellation of the contract. The Contractor will ship or deliver such items to the State at the Contractor's expense.
- 22.7.13 The Contractor will not permit the equipment to be tampered with or operated by individuals who are not trained in its proper handling and operation.
- 22.7.14 The Contractor agrees to provide secure, climate-controlled storage for all equipment used pursuant to this Contract.
- 22.8 Insurance: Contractor agrees to provide the State a certificate(s) of insurance, or a statement of self-insurance, naming the State as an additional insured under the policy(s) within sixty (60) days after execution of this contract.
 - 22.8.1 State Owned Equipment Loaned to Contractor: Contractor agrees to provide "All Risk" property floater insurance, or equivalent self-insurance, which provides replacement cost coverage on all State owned property loaned to Contractor by the State.
 - 22.8.2 Contractor may recover the cost of such insurance from the State in accordance with Clause 4, Section 5.1, Item a(5) of this contract.
 - 22.8.3 Contractor agrees to provide the State thirty (30) days advanced written notice of cancellation, non-renewal, or reductions in limits or coverage's or other changes to the policy(s).
- 22.9 The parties mutually agree that all capital equipment purchased with State funds remains the sole property of the State of Minnesota.
- 22.10 The parties mutually agree that all necessary and reasonable costs associated with a state-authorized emergency response to a hazardous materials incident incurred by the Contractor and authorized by the State, will be billed by the State to the responsible person, and managed by the State through a separate revolving account for such incidents. Contractor agrees that the State subrogates to the rights of the Contractor against the responsible person as defined in Minnesota Statutes § 299.A.52.

23. Survival of Terms

The following clauses survive the expiration or cancellation of this Contract: Indemnification; State Audits; Government Data Practices; Intellectual Property; Publicity and Endorsement; Governing Law, Jurisdiction, and Venue; and Data Disclosure. Any other Contract term that expressly states or by its nature shall survive, shall survive.

Exhibit B: Insurance Terms and Requirements

1. Notice to Contractor

- 1.1 The Contractor is required, if requested by the State, to submit Certificates of Insurance acceptable to the State as evidence of insurance coverage requirements prior to commencing work under this Contract.
- 1.2 Contractor shall not commence work under the Contract until it has obtained all the insurance described below. Contractor shall maintain such insurance in force and effect throughout the term of this Contract.
- 1.3 The failure of the Contractor to provide a Certificate of Insurance, if requested by the State, for the policies required under this Contract or renewals thereof, or failure of the insurance company to notify the State of the cancellation of policies required under this Contract shall not constitute a waiver by the State to the Contractor to provide such insurance.
- 1.4 The State reserves the right to immediately terminate this Contract if the Contractor is not in compliance with the insurance requirements and retains all rights to pursue any legal remedies against the Contractor. All insurance policies must be open to inspection by the State, and copies of policies must be submitted to the State's Authorized Representative upon written request.

2. Notice to Insurer

- 2.1 The Contractor's insurance company(ies) waives its right to assert the immunity of the State as a defense to any claims made under said insurance.
- 2.2 Insurance certificates, if requested by the State, shall be addressed as follows:
Nolan Pasell, State Fire Marshal Division
Email Address: Nolan.Pasell@state.mn.us

3. Additional Insurance Conditions. The following apply to the Contractor or the Contractor's subcontractor:

- 3.1 Contractor's policy(ies) shall be primary insurance to any other valid and collectible insurance available to the State with respect to any claim arising out of Contractor's performance under this Contract.
- 3.2 If Contractor receives a cancellation notice from an insurance carrier affording coverage herein, Contractor agrees to notify the State within five (5) business days with a copy of the cancellation notice, unless Contractor's policy(ies) contain a provision that coverage afforded under the policy(ies) will not be cancelled without at least thirty (30) days advance written notice to the State.
- 3.3 Contractor is responsible for payment of Contract related insurance premiums and deductibles.
- 3.4 If Contractor is self-insured, a Certificate of Self-Insurance shall be submitted to the State prior to beginning work pursuant to this Contract.
- 3.5 Contractor's policy(ies) shall include legal defense fees in addition to its policy limits with the exception of professional liability.
- 3.6 Contractor's insurance companies must either: (1) have an AM Best rating of A- (minus) and a Financial Size Category of VII or better, and be authorized to do business in the State of Minnesota; or (2) be domiciled in the State of Minnesota and have a Certificate of Authority/Compliance from the Minnesota Department of Commerce if they are not rated by AM Best.
- 3.7 An Umbrella or Excess Liability insurance policy may be used to supplement the Contractor's policy limits to satisfy the full policy limits required by the Contract.

4. Coverages. Contractor is required to maintain and furnish satisfactory evidence of the following insurance policies:

- 4.1 **Commercial General Liability Insurance.** Contractor is required to maintain insurance protecting it from claims for damages for bodily injury, including sickness or disease, death, and for care and loss of services as well as from claims for property damage, including loss of use which may arise from operations under the Contract whether the operations are by the Contractor or by a subcontractor or by anyone directly or indirectly employed by the Contractor under the contract. Insurance minimum limits are as follows:

\$2,000,000 – per occurrence
\$2,000,000 – annual aggregate
\$2,000,000 – annual aggregate – applying to Products/Completed Operations

The following coverages shall be included:

Premises and Operations Bodily Injury and Property Damage
Personal and Advertising Injury
Blanket Contractual Liability
Products and Completed Operations Liability

State of Minnesota named as an Additional Insured, to the extent permitted by law

- 4.2 **Commercial Automobile Liability Insurance.** Contractor is required to maintain insurance protecting it from claims for damages for bodily injury as well as from claims for property damage resulting from the ownership, operation, maintenance or use of all owned, hired, and non-owned autos which may arise from operations under this contract, and in case any work is subcontracted the contractor will require the subcontractor to maintain Commercial Automobile Liability insurance. Insurance minimum limits are as follows:

\$2,000,000 – per occurrence Combined Single limit for Bodily Injury and Property Damage

In addition, the following coverages should be included: Owned, Hired, and Non-owned Automobile.

Evidence of the subcontractor’s insurance shall be filed with the Contractor.

- 4.3 **Workers’ Compensation Insurance.** Statutory Compensation Coverage. Except as provided below, Contractor must provide Workers’ Compensation insurance for all its employees and, in case any work is subcontracted, Contractor will require the subcontractor to provide Workers’ Compensation insurance in accordance with the statutory requirements of the State, including Coverage B, Employer’s Liability. Insurance minimum limits are as follows:

\$100,000 – Bodily Injury by Disease per employee
\$500,000 – Bodily Injury by Disease aggregate
\$100,000 – Bodily Injury by Accident

The Contractor certifies it is in compliance with Minnesota Statutes § 176.181, subdivision 2, pertaining to workers' compensation insurance coverage.

Pursuant to Minnesota Administrative Rules 7514.2000, Liability and Workers’ Compensation Coverage, for the purposes of Minnesota Statutes Chapter 176, and section 3.736, workers’ compensation coverage for the Contractor’s HAZMAT team members by the State is initiated once a team is activated by the State, for operations authorized by the State, and the team is outside its normal geographic jurisdiction as identified in Appendix C.

- 4.4 **Professional Liability, Errors, and Omissions Insurance.** This policy will provide coverage for all claims the contractor may become legally obligated to pay resulting from any actual or alleged negligent act, error, or omission related to Contractor’s professional services required under the contract. Insurance **minimum** limits are as follows:

\$2,000,000 - per claim or event
\$2,000,000 - annual aggregate

Any deductible will be the sole responsibility of the Contractor and may not exceed \$50,000 without the written approval of the State. If the Contractor desires authority from the State to have a deductible in a

higher amount, the Contractor shall so request in writing, specifying the amount of the desired deductible and providing financial documentation by submitting the most current audited financial statements so that the State can ascertain the ability of the Contractor to cover the deductible from its own resources.

The retroactive or prior acts date of such coverage shall not be after the effective date of this Contract and Contractor shall maintain such insurance for a period of at least three (3) years, following completion of the work. If such insurance is discontinued, extended reporting period coverage must be obtained by Contractor to fulfill this requirement.

**APPENDIX A
PRIMARY RESPONSE AREA**

The Contractor's primary response area is described as follows:

The entire Minnesota counties of: Big Stone, Swift, Lac qui Parle, Chippewa, Yellow Medicine, Renville, Lyon, Redwood, Pipestone, Murray, Cottonwood, Rock, Nobles, Jackson

**APPENDIX B
SECONDARY RESPONSE AREA**

The Contractor's secondary response area is described as follows:

The entire State of Minnesota.

**APPENDIX C
NORMAL GEOGRAPHIC JURISDICTION**

The Contractor's normal geographic jurisdiction is described as follows:

The corporate limits of the City of Marshall, Minnesota

**APPENDIX D
POINT-OF-CONTACT FOR TEAM DISPATCHING**

The Contractor's single point-of-contact for purposes of State Hazardous Materials Response Team dispatching is:

Lyon County Dispatch Center

24-hour emergency telephone number: 507-537-7000

**APPENDIX E
DESIGNEES OF STATE'S AUTHORIZED REPRESENTATIVE**

**State's Authorized Representative:
James G. Smith, Fire Marshal**

**Designees of State's Authorized Representative:
John Kreuser, State Emergency Response Teams Coordinator
John Ehret, Fire Service Supervisor
Amanda Swenson, Chief Deputy Fire Marshal**

Authority of Designees:

- | | |
|---------------------------------|--|
| Clause 5, Section 5.1(a) | Authorization to approve Compensation |
| Clause 5, Section 5.1(b) | Authorization to approve increase of Contractor's budgeted administration costs more than 20% |
| Clause 5, Section 5.1(d) | Authorization to approve "Emergency Response Reimbursement" claims in excess of \$5,000.00 |
| Clause 5, Section 5.2(a) | Authorization to certify (approve) acceptance on each invoice submitted by Contractor corresponding to Clause 5.1 |
| Clause 5, Section 5.2(a) | Authorization to certify (approve) acceptance on each claims form submitted by Contractor corresponding to Clause 5, Section 5.1(d), Emergency Response Reimbursement |
| Exhibit A, Clause 9 | Authorization to give instructions to the Contractor concerning release of data to a requesting third party prior to the data being released |

The undersigned hereby delegates the authorities listed above to those persons identified as Designees of State's Authorized Representative. These authorities are delegated until revoked in writing.

By: _____

Date: _____

**James G. Smith
State Fire Marshal**

**APPENDIX F
PRIMARY AND ALTERNATE REPRESENTATIVES
TO THE HAZMAT RESPONSE TEAM**

The Contractor's primary and alternate representatives to the Hazardous Materials Regional Response Team are:

Primary Representative:

Quentin Brunsvold

Telephone Numbers: 507-530-7623 (work)

Email Address: quentin.brunsvold@ci.marshall.mn.us

Alternate Representative:

Brian Swalboski

Telephone Number: 507-828-9868

Email Address: Brian.Swalboski@ci.marshall.mn.us



CITY OF MARSHALL AGENDA ITEM REPORT

Meeting Date:	Tuesday, October 25, 2022
Category:	CONSENT AGENDA
Type:	ACTION
Subject:	Consider approval of the bills/project payments
Background Information:	Staff encourages the City Council Members to contact staff in advance of the meeting regarding these items if there are questions. Construction contract questions are encouraged to be directed to Director of Public Works, Jason Anderson at 537-6051 or Finance Director, Karla Drown at 537-6764
Fiscal Impact:	
Alternative/ Variations:	
Recommendations:	The following bills and project payments be authorized for payment.



Marshall, MN

Council Check Report

By Vendor Name

Date Range: 10/14/2022 - 10/25/2022

Vendor Number	Vendor Name	Payment Date	Payment Type	Discount Amount	Payment Amount	Number
Bank Code: AP-REG AP						
4549	A & B BUSINESS, INC	10/14/2022	EFT	0.00	2,174.37	11072
5813	ACE HOME & HARDWARE	10/14/2022	EFT	0.00	2,704.77	11073
5813	ACE HOME & HARDWARE	10/21/2022	EFT	0.00	77.67	11135
6128	ACTION CO LLC	10/14/2022	EFT	0.00	26.15	11074
0548	ACTION SPORTS INC	10/14/2022	EFT	0.00	45.99	11075
7026	ADA ENTERPRISES	10/21/2022	Regular	0.00	3,144.00	121904
7100	AH STOCK MANUFACTURING COMPANY	10/21/2022	Regular	0.00	400.95	121905
0567	ALEX AIR APPARATUS, INC	10/14/2022	EFT	0.00	1,364.70	11076
0578	AMAZON CAPITAL SERVICES	10/21/2022	EFT	0.00	765.48	11136
3761	AMERICAN BOTTLING CO.	10/21/2022	Regular	0.00	83.28	121906
0630	ARCTIC GLACIER	10/21/2022	Regular	0.00	676.95	121907
5447	ARTISAN BEER COMPANY	10/21/2022	EFT	0.00	1,718.90	11137
6883	AT&T MOBILITY II LLC	10/21/2022	Regular	0.00	38.23	121908
0658	AWARDS PLUS, INC.	10/14/2022	EFT	0.00	347.90	11077
0688	BELLBOY CORPORATION	10/21/2022	EFT	0.00	5,676.07	11138
0689	BEND RITE CUSTOM FABRICATION, INC.	10/21/2022	Regular	0.00	837.88	121909
0699	BEVERAGE WHOLESALERS, INC.	10/21/2022	Regular	0.00	76,959.96	121910
6482	BLOMBERG, GRANT	10/14/2022	EFT	0.00	2,005.00	11078
7097	BLUESTEM PRODUCTS LLC	10/21/2022	Regular	0.00	246.00	121914
0726	BORCH'S SPORTING GOODS, INC.	10/14/2022	EFT	0.00	1,243.00	11079
0018	BORDER STATES INDUSTRIES, INC.	10/14/2022	EFT	0.00	37.80	11080
0018	BORDER STATES INDUSTRIES, INC.	10/21/2022	EFT	0.00	60.26	11139
3829	BRAU BROTHERS	10/21/2022	EFT	0.00	596.00	11140
4457	BREAKTHRU BEVERAGE	10/14/2022	Regular	0.00	8,586.80	121870
4457	BREAKTHRU BEVERAGE	10/21/2022	Regular	0.00	6,567.85	121915
0728	BUFFALO RIDGE CONCRETE,INC	10/14/2022	EFT	0.00	525.85	11081
0728	BUFFALO RIDGE CONCRETE,INC	10/21/2022	EFT	0.00	615.00	11141
0774	BUREAU OF CRIMINAL APPREHENSION	10/14/2022	Regular	0.00	2,520.00	121872
6744	C&L DISTRIBUTING	10/21/2022	EFT	0.00	195.00	11142
6791	CAPITAL ONE	10/14/2022	Regular	0.00	530.17	121873
6791	CAPITAL ONE	10/21/2022	Regular	0.00	102.62	121917
0799	CARLOS CREEK WINERY, INC	10/21/2022	Regular	0.00	624.00	121918
0802	CARLSON & STEWART REFRIGERATION, INC.	10/21/2022	EFT	0.00	3,502.48	11143
0815	CATTOOR OIL COMPANY, INC	10/14/2022	EFT	0.00	4,423.25	11082
0815	CATTOOR OIL COMPANY, INC	10/21/2022	EFT	0.00	3,975.58	11144
0836	CHARTER COMMUNICATIONS, LLC	10/14/2022	EFT	0.00	106.80	11083
0836	CHARTER COMMUNICATIONS, LLC	10/21/2022	EFT	0.00	11.99	11145
7058	CHEPA, RYAN	10/14/2022	EFT	0.00	106.87	11084
5733	CLARITY TELECOM, LLC	10/14/2022	EFT	0.00	342.07	11085
5733	CLARITY TELECOM, LLC	10/21/2022	EFT	0.00	2,845.82	11146
0920	CULLIGAN WATER CONDITIONING OF MARSHALL	10/21/2022	Regular	0.00	92.25	121919
0934	D & G EXCAVATING INC	10/14/2022	EFT	0.00	135.00	11086
3819	DACOTAH PAPER CO	10/14/2022	EFT	0.00	122.72	11087
3819	DACOTAH PAPER CO	10/21/2022	EFT	0.00	2,824.35	11147
7102	DAHLHEIMER BEVERAGE	10/21/2022	Regular	0.00	1,117.00	121920
7075	DEMUTH, ROGER	10/21/2022	EFT	0.00	50.00	11148
4794	DEPOVER, PERRY	10/14/2022	EFT	0.00	120.93	11088
6205	DESMET, JASMINE	10/21/2022	EFT	0.00	56.00	11149
5731	DOLL DISTRIBUTING	10/21/2022	EFT	0.00	27,731.20	11150
7095	DRESSEN, NANCY	10/14/2022	Regular	0.00	25.00	121874
5984	DROWN, KARLA	10/21/2022	EFT	0.00	74.38	11151
1020	DUININCK BROS., INC.	10/14/2022	EFT	0.00	813.06	11089
1020	DUININCK BROS., INC.	10/21/2022	EFT	0.00	8,427.77	11152
1035	ECOLAB PEST ELIMINATION SERVICES	10/14/2022	EFT	0.00	835.23	11090

Council Check Report

Date Range: 10/14/2022 - 10/25/2022

Vendor Number	Vendor Name	Payment Date	Payment Type	Discount Amount	Payment Amount	Number
1037	ECOWATER SYSTEMS	10/21/2022	EFT	0.00	50.00	11153
1042	EICKHOFF ENTERPRISES INC	10/21/2022	Regular	0.00	1,000.00	121921
4753	ENTERPRISE LEASING CO	10/14/2022	EFT	0.00	324.82	11091
1090	FASTENAL COMPANY	10/14/2022	EFT	0.00	175.63	11092
1090	FASTENAL COMPANY	10/21/2022	EFT	0.00	30.62	11154
7073	FIXEN CHIROPRACTIC	10/14/2022	Regular	0.00	40.00	121875
1122	FLAHERTY & HOOD, P.A.	10/21/2022	EFT	0.00	735.00	11155
1158	GALLS INC	10/21/2022	EFT	0.00	580.24	11156
6478	GOPHER STATE ONE CALL	10/14/2022	EFT	0.00	260.55	11093
1201	GRAINGER INC	10/21/2022	EFT	0.00	469.78	11157
1208	GREAT PLAINS NATURAL GAS COMPANY	10/14/2022	Regular	0.00	26.85	121876
7080	HANCOCK CONCRETE PRODUCTS LLC	10/14/2022	Regular	0.00	5,716.80	121877
1243	HARDWARE HANK	10/21/2022	EFT	0.00	215.76	11158
1247	HARTS HEATING & REFRIGERATION INC	10/14/2022	Regular	0.00	588.90	121878
1268	HELENA CHEMICAL COMPANY	10/14/2022	Regular	0.00	1,463.78	121879
1271	HENLE PRINTING COMPANY	10/21/2022	EFT	0.00	128.67	11159
1311	HYVEE FOOD STORES INC	10/14/2022	Regular	0.00	335.16	121880
1311	HYVEE FOOD STORES INC	10/21/2022	Regular	0.00	11.98	121922
1325	ICMA RETIREMENT TRUST #300877	10/14/2022	Regular	0.00	50.00	121881
6951	IKI INC.	10/14/2022	Regular	0.00	44.00	121882
1358	INTERNAL REVENUE SERVICE	10/14/2022	Bank Draft	0.00	27,835.16	DFT0002098
1358	INTERNAL REVENUE SERVICE	10/14/2022	Bank Draft	0.00	24,132.35	DFT0002099
1358	INTERNAL REVENUE SERVICE	10/14/2022	Bank Draft	0.00	8,446.28	DFT0002100
6540	INTERNATIONAL CHEMTEX, LLC	10/14/2022	EFT	0.00	976.97	11094
5017	JIM'S CLOTHING & SPORTING GOODS	10/21/2022	Regular	0.00	919.90	121923
1399	JOHNSON BROTHERS LIQUOR COMPANY	10/14/2022	EFT	0.00	1,109.79	11095
1399	JOHNSON BROTHERS LIQUOR COMPANY	10/21/2022	EFT	0.00	24,098.52	11160
7094	KAISER, DANIEL J.	10/14/2022	Regular	0.00	500.00	121883
7101	KELLY, BENJAMIN	10/21/2022	EFT	0.00	334.00	11161
1417	KENNEDY & GRAVEN, CHARTERED	10/14/2022	EFT	0.00	1,148.00	11096
3564	KESTELOOT ENTERPRISES, INC	10/21/2022	EFT	0.00	130.49	11162
5095	KIBBLE EQUIPMENT LLC	10/14/2022	EFT	0.00	132.37	11097
7093	KORMAN, JOAN	10/14/2022	Regular	0.00	500.00	121884
4140	KRUSE FORD-LINCOLN-MERCURY, INC	10/14/2022	EFT	0.00	97.17	11098
5138	L & A SYSTEMS, LLC	10/21/2022	EFT	0.00	13,500.00	11163
3653	LANGUAGE LINE SERVICES	10/14/2022	EFT	0.00	724.22	11099
1483	LEAGUE OF MINNESOTA CITIES INS TRUST	10/14/2022	Regular	0.00	439,739.00	121885
1483	LEAGUE OF MINNESOTA CITIES INS TRUST	10/21/2022	Regular	0.00	1,964.42	121924
1483	LEAGUE OF MINNESOTA CITIES INS TRUST	10/21/2022	Regular	0.00	1,507.20	121925
6068	LEHMAN, CHRISTINE	10/21/2022	EFT	0.00	66.00	11164
1506	LOCATORS & SUPPLIES INC	10/21/2022	EFT	0.00	1,676.95	11165
3816	LUTHERAN SOCIAL SERVICES	10/14/2022	Regular	0.00	21.00	121892
1531	LYON COUNTY AUDITOR-TREASURER	10/14/2022	EFT	0.00	2,500.00	11100
1545	LYON COUNTY HIGHWAY DEPARTMENT	10/21/2022	EFT	0.00	12,460.01	11166
1548	LYON COUNTY LANDFILL	10/14/2022	EFT	0.00	30.00	11101
1552	LYON COUNTY RECORDER	10/14/2022	EFT	0.00	157.50	11102
1555	LYON LINCOLN ELECTRIC COOPERATIVE INC	10/21/2022	Regular	0.00	37.35	121926
6292	MADDEN, GALANTER, HANSEN, LLP	10/21/2022	EFT	0.00	180.00	11167
1575	MAILBOXES & PARCEL DEPOT	10/21/2022	EFT	0.00	25.40	11168
1604	MARSHALL AREA CHAMBER OF COMMERCE	10/21/2022	EFT	0.00	30.00	11169
6860	MARSHALL GIRL'S VARSITY HOCKEY	10/21/2022	Regular	0.00	1,095.00	121927
1623	MARSHALL INDEPENDENT, INC	10/21/2022	Regular	0.00	1,965.58	121928
6018	MARSHALL M CLUB	10/21/2022	Regular	0.00	787.50	121930
1633	MARSHALL MUNICIPAL UTILITIES	10/14/2022	EFT	0.00	2,072.17	11103
1633	MARSHALL MUNICIPAL UTILITIES	10/21/2022	EFT	0.00	93,897.70	11170
1635	MARSHALL NORTHWEST PIPE FITTINGS INC	10/21/2022	EFT	0.00	11.84	11173
1637	MARSHALL PUBLIC SCHOOLS	10/14/2022	EFT	0.00	20,700.61	11104
1637	MARSHALL PUBLIC SCHOOLS	10/21/2022	EFT	0.00	949.23	11174
3545	MARSHALL RADIO	10/21/2022	EFT	0.00	2,000.00	11175
1652	MARSHALL VOLUNTEER FIRE RELIEF ASSOCIATION	10/21/2022	Regular	0.00	110,666.97	121931
5924	MAXWELL FOOD EQUIPMENT	10/21/2022	Regular	0.00	49.61	121932

Council Check Report

Date Range: 10/14/2022 - 10/25/2022

Vendor Number	Vendor Name	Payment Date	Payment Type	Discount Amount	Payment Amount	Number
6586	MCDYER TOOLS	10/14/2022	Regular	0.00	308.75	121893
4980	MENARDS INC	10/14/2022	EFT	0.00	688.95	11105
4980	MENARDS INC	10/21/2022	EFT	0.00	28.92	11176
6276	MIDSTATES EQUIPMENT & SUPPLY	10/14/2022	EFT	0.00	2,028.25	11106
6276	MIDSTATES EQUIPMENT & SUPPLY	10/21/2022	EFT	0.00	12,183.80	11177
4281	MIDWEST GLASS INC.	10/14/2022	Regular	0.00	517.09	121894
1818	MINNESOTA DEPARTMENT OF REVENUE	10/14/2022	Bank Draft	0.00	11,621.11	DFT0002101
1808	MINNESOTA MUNICIPAL UTILITIES ASSOC	10/21/2022	EFT	0.00	682.00	11178
3669	MINNESOTA STATE RETIREMENT SYSTEM	10/14/2022	Bank Draft	0.00	8,850.61	DFT0002095
1839	MINNESOTA VALLEY TESTING LABS INC	10/14/2022	EFT	0.00	220.00	11107
1839	MINNESOTA VALLEY TESTING LABS INC	10/21/2022	EFT	0.00	899.00	11179
1757	MN CHILD SUPPORT PAYMENT CENTER	10/14/2022	Bank Draft	0.00	386.70	DFT0002089
1757	MN CHILD SUPPORT PAYMENT CENTER	10/14/2022	Bank Draft	0.00	222.88	DFT0002090
1757	MN CHILD SUPPORT PAYMENT CENTER	10/14/2022	Bank Draft	0.00	546.74	DFT0002091
1807	MN MUNICIPAL BEVERAGE ASSOCIATION	10/14/2022	Regular	0.00	20.00	121895
6955	MOBERG, E.J.	10/14/2022	EFT	0.00	74.38	11108
1864	MONTES ELECTRIC INC	10/14/2022	Regular	0.00	3,234.15	121896
1877	MOTION INDUSTRIES INC	10/21/2022	EFT	0.00	147.00	11180
2512	NATIONWIDE RETIREMENT	10/14/2022	Bank Draft	0.00	230.77	DFT0002086
1938	NEWMAN SIGNS	10/21/2022	EFT	0.00	305.56	11181
1939	NFPA	10/14/2022	Regular	0.00	347.95	121898
1945	NORM'S GTC	10/14/2022	Regular	0.00	87.35	121899
1945	NORM'S GTC	10/21/2022	Regular	0.00	426.68	121933
1986	NORTH CENTRAL INTERNATIONAL, INC	10/14/2022	EFT	0.00	35.35	11109
1986	NORTH CENTRAL INTERNATIONAL, INC	10/14/2022	EFT	0.00	10,000.00	11110
1986	NORTH CENTRAL INTERNATIONAL, INC	10/21/2022	EFT	0.00	3,511.41	11182
1961	NORTHERN SAFETY COMPANY INC	10/21/2022	EFT	0.00	187.36	11183
4566	NSI SOLUTIONS	10/21/2022	EFT	0.00	87.00	11184
6463	OFFICE OF MNIT SERVICES	10/21/2022	Regular	0.00	695.15	121934
5891	ONE OFFICE SOLUTION	10/14/2022	EFT	0.00	19.11	11111
3809	O'REILLY AUTOMOTIVE STORES, INC	10/14/2022	EFT	0.00	516.87	11112
2026	PEPSI COLA BOTTLING OF PIPESTONE MN INC	10/21/2022	EFT	0.00	121.50	11185
2028	PERA OF MINNESOTA REG	10/14/2022	Bank Draft	0.00	54,435.21	DFT0002093
2030	PETERSON, ALEX	10/21/2022	EFT	0.00	56.00	11186
2036	PHILLIPS WINE AND SPIRITS INC	10/21/2022	EFT	0.00	34,028.12	11187
3557	POMP'S TIRE SERVICE, INC.	10/14/2022	EFT	0.00	735.00	11113
2065	POWER PROCESS EQUIPMENT INC	10/14/2022	EFT	0.00	337.76	11114
2065	POWER PROCESS EQUIPMENT INC	10/21/2022	EFT	0.00	1,033.73	11188
6166	PULVER MOTOR SVC, LLC	10/14/2022	EFT	0.00	160.00	11115
6166	PULVER MOTOR SVC, LLC	10/21/2022	EFT	0.00	80.00	11189
2096	QUARNSTROM & DOERING, PA	10/14/2022	EFT	0.00	1,454.75	11116
2112	R AND G CONSTRUCTION COMPANY	10/14/2022	EFT	0.00	275,350.08	11117
7096	ROBINSON APPRAISAL & ASSOCIATES	10/14/2022	Regular	0.00	1,500.00	121901
2201	RUNNING SUPPLY, INC	10/14/2022	EFT	0.00	304.32	11118
2201	RUNNING SUPPLY, INC	10/21/2022	EFT	0.00	22.75	11190
6576	SAFETYFIRST SPECIALTY CONTRACTING, INC	10/21/2022	Regular	0.00	3,024.00	121935
6251	SHRED RIGHT	10/14/2022	EFT	0.00	40.00	11119
5243	SIR LINES-A-LOT, LLC	10/14/2022	Regular	0.00	14,531.00	121902
3495	SMSU	10/14/2022	EFT	0.00	300.00	11120
4855	SOUTHERN GLAZER'S	10/21/2022	EFT	0.00	13,117.13	11191
2309	SOUTHWEST COACHES INC	10/14/2022	EFT	0.00	1,210.00	11121
2318	SOUTHWEST SANITATION INC.	10/14/2022	EFT	0.00	3,547.16	11122
5922	SRF CONSULTING GROUP, INC.	10/14/2022	EFT	0.00	999.68	11123
2373	STREICHERS	10/14/2022	EFT	0.00	36.97	11124
3315	SUSSNER CONSTRUCTION	10/14/2022	EFT	0.00	45,040.00	11125
2395	SWEDE'S SERVICE CENTER	10/14/2022	Regular	0.00	912.10	121903
6277	TALKING WATERS BREWING CO, LLC	10/21/2022	EFT	0.00	735.00	11193
6137	TEIGS LAWN CARE & LANDSCAPING, LLC	10/21/2022	Regular	0.00	100.00	121936
0875	THE COMPUTER MAN INC	10/21/2022	EFT	0.00	2,414.75	11194
2428	TITAN MACHINERY	10/14/2022	EFT	0.00	136.00	11126
2428	TITAN MACHINERY	10/21/2022	EFT	0.00	705.94	11195

Council Check Report

Date Range: 10/14/2022 - 10/25/2022

Vendor Number	Vendor Name	Payment Date	Payment Type	Discount Amount	Payment Amount	Number
2429	TKDA	10/21/2022	EFT	0.00	1,485.00	11196
7099	TROPHIES PLUS, INC.	10/21/2022	Regular	0.00	363.25	121937
6156	TRUE BRANDS	10/14/2022	EFT	0.00	66.78	11127
5106	ULINE	10/21/2022	EFT	0.00	191.03	11197
2499	US BANK	10/14/2022	EFT	0.00	1,050.00	11128
2511	USA BLUE BOOK	10/14/2022	EFT	0.00	53.86	11129
2511	USA BLUE BOOK	10/21/2022	EFT	0.00	390.10	11198
3443	VALIC DEFERRED COMP	10/14/2022	Bank Draft	0.00	941.61	DFT0002087
3443	VALIC DEFERRED COMP	10/14/2022	Bank Draft	0.00	1,405.77	DFT0002088
4489	VERIZON WIRELESS	10/14/2022	EFT	0.00	35.01	11130
4489	VERIZON WIRELESS	10/14/2022	EFT	0.00	35.01	11131
4489	VERIZON WIRELESS	10/14/2022	EFT	0.00	49.04	11132
4489	VERIZON WIRELESS	10/21/2022	EFT	0.00	400.24	11199
4489	VERIZON WIRELESS	10/21/2022	EFT	0.00	1,447.55	11200
2538	VIKING COCA COLA BOTTLING COMPANY	10/21/2022	EFT	0.00	803.60	11201
4594	VINOCOPIA INC	10/21/2022	EFT	0.00	3,910.44	11202
6085	VOYA - INVESTORS CHOICE	10/14/2022	Bank Draft	0.00	1,734.21	DFT0002096
5288	WEST CENTRAL COMMUNICATIONS, INC	10/14/2022	EFT	0.00	79.50	11133
2591	WESTERN PRINT GROUP	10/21/2022	EFT	0.00	334.10	11203
2605	WINE MERCHANTS	10/21/2022	EFT	0.00	2,114.35	11204
6379	WINEBOW	10/21/2022	EFT	0.00	549.00	11205
2632	ZIEGLER INC	10/14/2022	EFT	0.00	1,402.42	11134

Bank Code AP Summary

Payment Type	Payable Count	Payment Count	Discount	Payment
Regular Checks	117	54	0.00	697,651.41
Manual Checks	0	0	0.00	0.00
Voided Checks	0	0	0.00	0.00
Bank Drafts	13	13	0.00	140,789.40
EFT's	266	131	0.00	686,644.05
	396	198	0.00	1,525,084.86

All Bank Codes Check Summary

Payment Type	Payable Count	Payment Count	Discount	Payment
Regular Checks	117	54	0.00	697,651.41
Manual Checks	0	0	0.00	0.00
Voided Checks	0	0	0.00	0.00
Bank Drafts	13	13	0.00	140,789.40
EFT's	266	131	0.00	686,644.05
	396	198	0.00	1,525,084.86

Fund Summary

Fund	Name	Period	Amount
999	POOLED CASH FUND	10/2022	1,525,084.86
			1,525,084.86

**CITY OF MARSHALL, MINNESOTA
PRIOR AND CURRENT YEARS CONSTRUCTION CONTRACTS**

10/25/2022

PROJECT #:	Coding	DATE	CONTRACTOR:	ORIGINAL CONTRACT AMOUNT:	CHANGE ORDERS	CURRENT CONTRACT AMOUNT	2019 Prior Payments	2020 Prior Payments	2021 Prior Payments	2022 Prior Payments	PYMTS THIS MEETING:	RETAINAGE	BALANCE:	PERCENT COMPLETE
W13	602-49500-55120	5/28/2019	WWTF Improvement Project	Magney Construction, Inc.	14,074,300.00	(26,609.74)	14,047,690.26	4,099,265.87	6,918,924.06	3,029,500.33		-	-	100.00%
CH1	494-43300-55120	11/12/2019	City Hall Renovation	Brennan Companies	5,030,200.00	749,360.00	5,779,560.00		3,039,722.04	2,661,221.96	66,794.00	11,822.00	-	100.00%
Z83	479-43300-55170	2/23/2021	James Ave/Camden Dr Reconstruction	Kuechle Underground	849,244.50	8,701.86	857,946.36			779,179.36	78,767.00	-	-	100.00%
Z88	479-43300-55170	4/13/2021	State Aid Overlay	Duininck, Inc	1,924,600.45	(33,840.43)	1,890,760.02			1,879,301.49	11,458.53	-	-	100.00%
PK-001	401-45200-55130	8/25/2021	Independence Park Trail Replacement	A & C Excavating, LLC	375,659.10	6,940.50	382,599.60			109,320.20	243,828.63	18,586.78	10,863.99	97.16%
SWM-007	630-49600-55170	10/12/2021	Independence Park Pond Forebay Expansion	Towne & Country Excavating LLC	229,255.50	(1,134.66)	228,120.84				228,120.84	-	-	100.00%
AP-005	101-43400-55120	10/12/2021	A/D Building Roof Repair	Gag Sheet Metal, Inc.	37,200.00	45,399.00	82,599.00			51,879.00	30,720.00	-	-	100.00%
ST-002	495-43300-55170	2/8/2022	Bituminous Overlay on Various City Streets	Duininck, Inc	560,573.35	10,921.45	571,494.80				619,416.96	32,523.82	(80,445.98)	114.08%
ST-003	480-43300-55170	2/8/2022	1st/Greeley/Williams Reconstruction	R & G Construction Co.	1,647,498.69	2,500.00	1,649,998.69			1,089,938.71	275,350.08	71,857.30	212,852.60	87.10%
ST-001	101-43300-53425	2/22/2022	Chip Seals	Pearson Bros., Inc.	222,455.10	(15,453.10)	207,002.00				207,002.00	-	-	100.00%
ST-004	480-43300-55170	2/22/2022	Halbur Road Reconstruction	Duininck, Inc	1,142,009.72	41,873.66	1,183,883.38				936,277.23	49,277.77	198,328.38	83.25%
ST-006 (Z79)	495-43300-55130	5/10/2022	School Pedestrian Crossing Improvements	Duininck, Inc	480,250.35		480,250.35				282,681.21	14,877.96	182,691.18	61.96%
ST-005	480-43300-55170	5/24/2022	Rose Parking Lot Reconstruction	R & G Construction Co.	140,177.51	19,600.57	159,778.08				159,778.08	-	0.00	100.00%
ST-023	480-43300-55170	5/24/2022	W. Lyon St.(College to 1st) Reconstruction	R & G Construction Co.	409,645.10	1,161.35	410,806.45				381,380.25	20,072.65	9,353.55	97.72%
ST-024	480-43300-55170	7/12/2022	Baldwin Parking Lot Reconstruction	R & G Construction Co.	159,515.77		159,515.77						159,515.77	0.00%
					27,282,585.14	809,420.46	28,092,005.60	4,099,265.87	9,958,646.10	8,510,402.34	275,350.08	219,018.28	693,159.49	

Presenter:	Quentin Brunsvold
Meeting Date:	Tuesday, October 25, 2022
Category:	NEW BUSINESS
Type:	INFO/ACTION
Subject:	Aerial Apparatus Replacement
Background Information:	<p>The Marshall Fire Department currently owns a 1994 Pierce aerial apparatus ladder truck. The aerial apparatus was refurbished in 2012 and was initially scheduled to be replaced as part of the 2020 Capital Improvement Plan. A decision was made to extend the life of the aerial apparatus for replacement in 2025.</p> <p>In 2022, fire department staff formed a committee to evaluate the needs and how best the aerial apparatus could be used for both fire purposes and technical rescue purposes. Specifications were determined with the goal to ensure the apparatus could fit inside the existing fire hall without modifications to the building. The committee evaluated and operated aerial trucks from different cities in Minnesota and determined a middle-mounted platform would meet all the requirements.</p> <p>Two bid proposals were received for the build of the aerial apparatus. Both companies are part of cooperative purchasing organizations recognized by the State of Minnesota. (Sourcewell Consortium Pricing & HGACBuy Cooperative Purchasing Program)</p> <ol style="list-style-type: none"> 1. MacQueen Equipment LLC: (Pierce): \$1,813,107 Estimated Delivery: December 2024 to April 2025 (27-31 months) 2. General Safety Fire Apparatus: (Rosenbauer): \$1,470,838 Estimated Delivery: April 2024 (600 days) <p>The Equipment Review Committee listened to a presentation from Fire Chief Brunsvold and Deputy Fire Chief Olson and reviewed the specifications and options. It was agreed upon by all parties to move forward with the General Safety Fire Apparatus (Rosenbauer) bid proposal. The recommendation was to work with city administration/finance to determine funding options that could be brought before City Council.</p> <p>Both bid proposals provide discounts for prepayment, ranging from 3.68% (MacQueen) to 4.16% (General Safety). After meetings with city administration on funding, it was determined that prepayment is not a viable option. Proposed bonding would take place in 2024 when the apparatus is scheduled to be completed.</p> <p>Additional funding could come through the following sources:</p> <ol style="list-style-type: none"> a) American Firefighter Grant (FEMA) b) American Rescue Plan Act (Lyon County) c) Sale of current aerial apparatus

Fiscal Impact:	\$1,470,838.00 to be bonded for in 2024
Alternative/ Variations:	None
Recommendations:	Consider awarding bid for construction of aerial apparatus to General Safety Apparatus (Rosenbauer) for \$1,470,838.00.

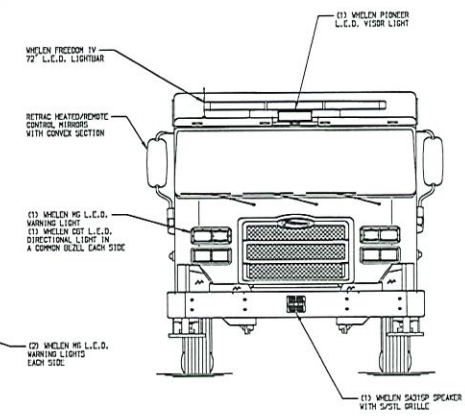
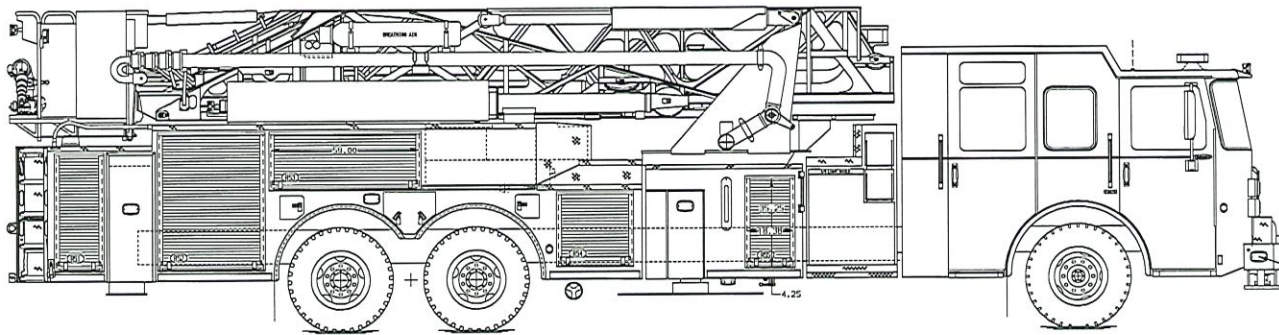

WHELEN FREEDOM IV
72" L.E.D. LIGHTBAR

RETRACT HEATED/POHTE
CONTROL MIRRORS
WITH CONVEY SECTION

(13) WHELEN W5 L.E.D.
WARNING LIGHT

(13) WHELEN W5 L.E.D.
DIRECTIONAL LIGHT IN
A COMMON BEZEL EACH SIDE

(12) WHELEN W5 L.E.D.
WARNING LIGHTS
EACH SIDE

(13) WHELEN S435P SPEAKER
WITH SPEIL GRILLE

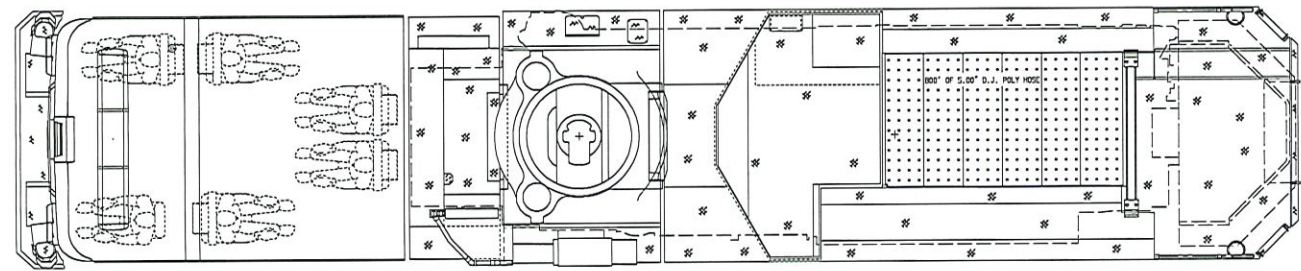

BODY 100' Ascendant Aerial Tower Alum Body COMPT, LEFT SIDE FULL Height RollUp Doors COMPT, RIGHT SIDE FULL Height RollUp Doors	WATER TANK 300 Gallon Poly Water Tank Foam System Foam System Not Required Foam Cell Foam Cell Not Required
---	---

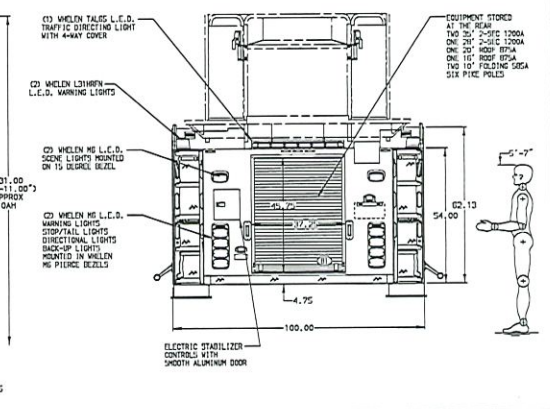
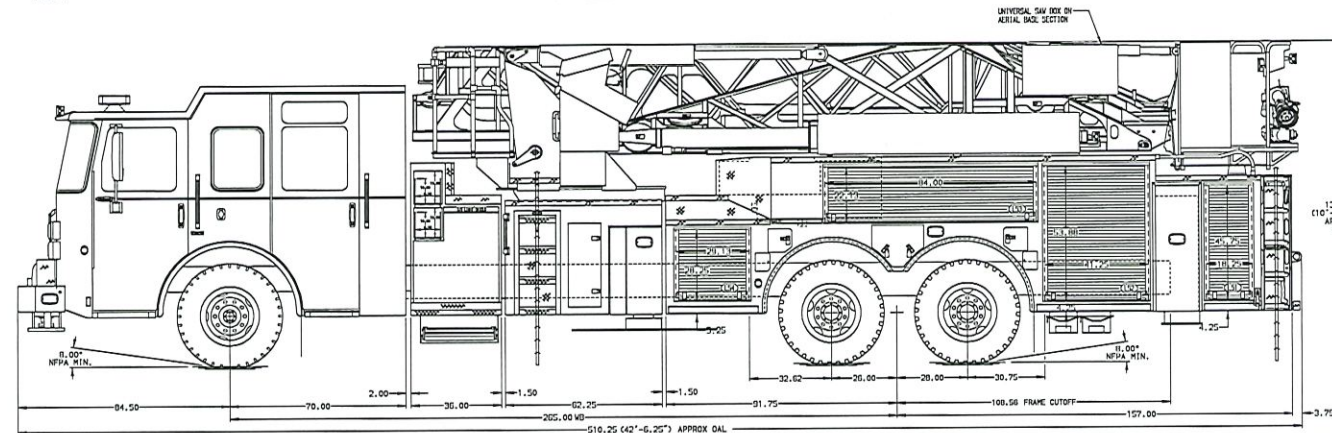

(13) WHELEN TALES L.E.D.
TRAFFIC DIRECTING LIGHT
WITH ARMY COVER

(12) WHELEN L318RN
L.E.D. WARNING LIGHTS

(12) WHELEN W5 L.E.D.
SCENE LIGHTS MOUNTED
ON 15 DEGREE BEZEL

(12) WHELEN W5 L.E.D.
WARNING LIGHTS
STOP/PAUSE LIGHTS
DIRECTIONAL LIGHTS
MOUNTED IN WHELEN
W6 PIERCE BEZELS

ELECTRIC STABILIZER
CONTROLS WITH
SMOOTH ALUMINUM DOOR

EQUIPMENT STORED
AT THE REAR

TWO 20" 2-SIDE 1200A
ONE 20" 2-SIDE 1200A
ONE 20" HOBI 1200A
ONE 10" HOBI 1200A
TWO 10" FOLDING SEAT
SIX PILE POLES

131.00
(10" - 11.00")
APPROX
OAH

62.13
54.00
100.00
4.75

11.00" NFA MIN.

11.00" NFA MIN.

3.25

30.75

28.00

26.00

32.62

62.25

1.50

36.00

2.00

70.00

84.50

265.00 WD

516.25 (42" - 6.25") APPROX OAL

UNIVERSAL SAW BOX ON
AERIAL BASK SECTION

CHASSIS Enforcer Chassis ENGINE 525 HP Cummins X12 Engine	CAB 7010 Enforcer Cab BUMPER 15" Painted Aluminum	AXLE, FRONT, CUSTOM 24,000 lb TAC-4 Axle AXLE, REAR 52,000 lb Meritor Axle	TRANSMISSION Allison 5th Gen, 4000 EYS P	PUMPHOUSE 36" Control Zone Side Mount PUMP 2000 GPM Waterous 5100	CROSSLAYS, 1.50" C2 1.50", Min Trugs, 200" CROSSLAYS, 2.50" 2.50", Crosslay Not Required	SPEEDLAYS SpeedLays Not Required GENERATOR Generator Not Required	SAFETY Side Roll and Frontal Impact Protection	CUSTOMER APPROVAL APPROVED BY: _____ DATE: _____		JOB NO. —																							
<table border="1"> <tr> <td>CHASSIS DATA</td> <td>TITLE</td> <td>SCALE</td> <td>DATE</td> </tr> <tr> <td>MAKE</td> <td>FOR</td> <td>1:24</td> <td></td> </tr> <tr> <td>PIERCE</td> <td>Marshall AAT Tower</td> <td></td> <td></td> </tr> <tr> <td>MODEL</td> <td>DWG</td> <td></td> <td></td> </tr> <tr> <td>NO.</td> <td></td> <td></td> <td></td> </tr> </table>										CHASSIS DATA	TITLE	SCALE	DATE	MAKE	FOR	1:24		PIERCE	Marshall AAT Tower			MODEL	DWG			NO.				<table border="1"> <tr> <td>CHECKED BY</td> <td></td> </tr> <tr> <td>DRAWN BY</td> <td></td> </tr> </table>	CHECKED BY		DRAWN BY
CHASSIS DATA	TITLE	SCALE	DATE																														
MAKE	FOR	1:24																															
PIERCE	Marshall AAT Tower																																
MODEL	DWG																																
NO.																																	
CHECKED BY																																	
DRAWN BY																																	
<p>NOTE DIMENSIONS SHOWN ARE APPROXIMATE AND ARE SUBJECT TO MINOR DEVIATIONS AS MAY OCCUR OR BE NECESSARY IN CONSTRUCTION. MINOR DETAILS NOT SHOWN.</p> <ol style="list-style-type: none"> 1. SHELF/LIF RECEPTACLE WITH ORIGINAL SUPPLY WITH-SEAT LOCATED ON DRIVER SIDE OF THE CAB 2. AIR TALLE WITH SYSTEM/CT COUPLING IN THE DRIVER SIDE SEATWELL 3. BATTERY CHARGER LOCATED PER ORDER 4. BATTERY CHARGE INDICATOR LOCATED ON THE DRIVER SIDE SEAT RISER 5. ADJUSTABLE SHELVES LOCATED PER ORDER 6. NON-HEATED AERIAL HOIST/CL 7. 3-in-1 LINED/ROD BRACKET AT AERIAL BASKET 																																	

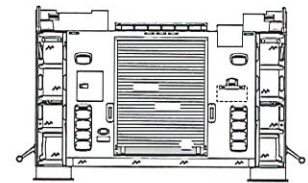
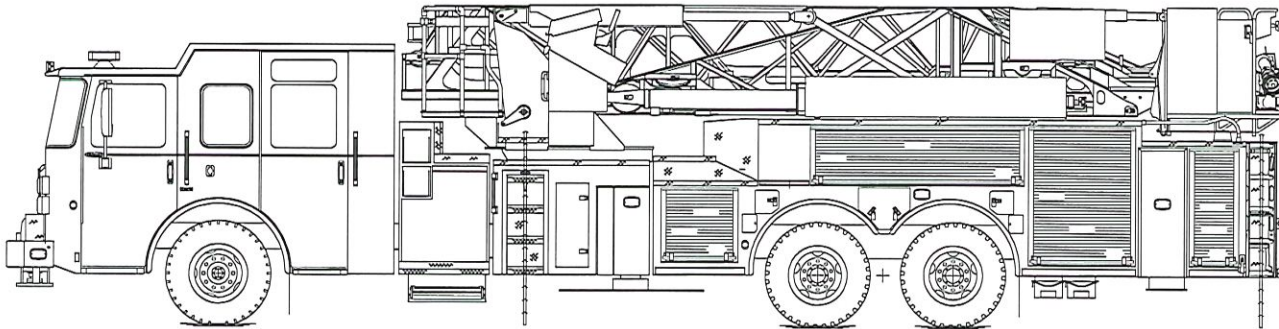
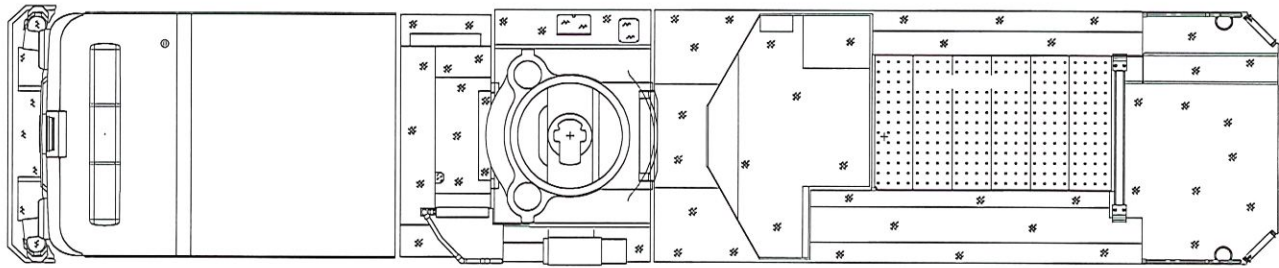
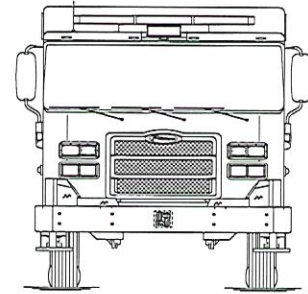
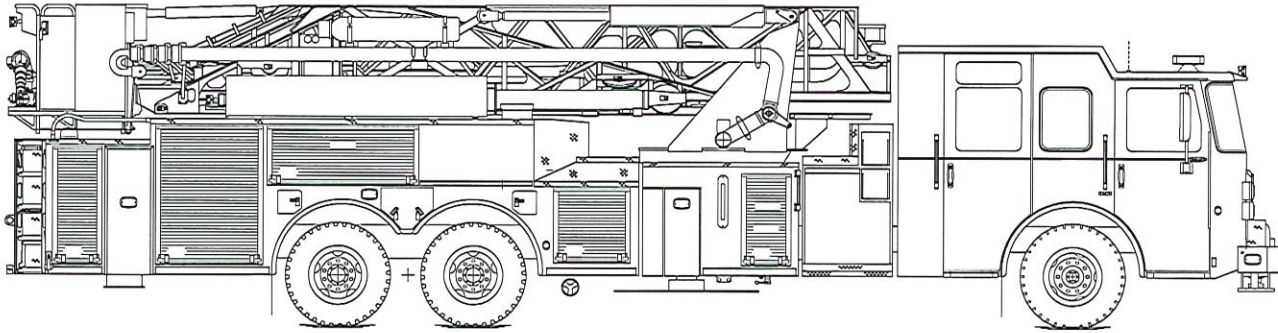

NOTE
LAYOUT AND SIZES PROVIDED BY CUSTOMERS
MAY VARY DUE TO AVAILABLE WORKING SPACE.

COLOR LEGEND	
PINK	LETTERING (VINYL OR REFLECTIVE)
ORANGE	STRIPING (VINYL OR REFLECTIVE)
GREEN	GOLD LEAF
YELLOW	CUSTOMER FURNISHED PRODUCT

CUSTOMER APPROVAL

APPROVED BY:
DATE:

REV	DATE	BY	CHK

CHASSIS DATA
MAKE
PIERCE
MODEL
DWC NO.

TITLE
LETTERING, STRIPING, AND PAINTING INSTRUCTIONS
FOR
Marshall AAT Tower
LSP-LP



JOB NO.	-
SCALE	1:24
DATE	
DRAWN BY	-
CHECKED BY	-
SHEET SIZE	D
SHEET NO.	1 of 1

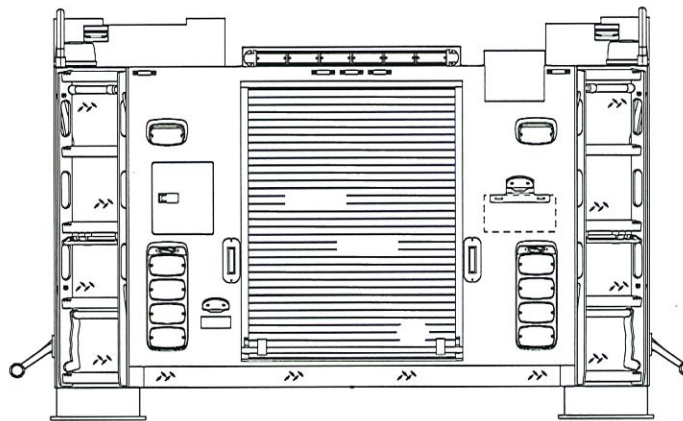

CUSTOMER APPROVAL

APPROVED BY: _____

DATE: _____

NOTE: PLEASE REVIEW CHEVRON COVERAGE AND DOOR MATERIAL PER PULSE OPTIONS. NON-RELATED OR NON-CRITICAL MINOR DEVIATIONS MAY EXIST.

 MANUFACTURING INC.		JOB NO.	-
		SCALE	1 : 24
TITLE	CHEVRON DRAWING	DRAWN BY	-
FOR	Marshall AAT Tower	DATE	06MAY22
DWG NO.	CHEVRON-CD	SHEET SIZE	SHEET NO.
		A	1 OF 1

Item 9.



PERFORM. LIKE NO OTHER.

MINNESOTA ILLINOIS INDIANA MISSOURI NEBRASKA NORTH DAKOTA SOUTH DAKOTA

EM-102

August 10, 2022

Assistant Chief Jake Olsen
City of Marshall Fire Department
201 East Saratoga Street
Marshall, MN 56258

Subject: **Proposal for one (1) Pierce Enforcer 100' Aerial Tower
Proposal / Bid 1072**

Dear Assistant Chief Olsen,

With regard to the above subject, please find attached our completed proposal.

Pricing, is as follows, including 100% prepay option.

Pricing Summary:

Sale Price – **\$1,813,107.00***
**Sourcewell Consortium Pricing, Member ID 2315.*

100% Performance Bond:

Included in the above price.

100% Prepayment Option:

Should the City of Marshall Fire Department elect to make a 100% prepayment at contract execution, a discount of (\$66,872.00) can be subtracted from the above "Sale Price" resulting in a revised contract price of **\$1,746,235.00**.

Terms and Conditions:

- Taxes – Not Applicable
- Freight – F.O.B. – Appleton, WI / Shipping to Marshall, MN
- Terms – Net due prior to vehicle(s) release at the Pierce Manufacturing Plant (Appleton, WI). Net due at Contract signing for **Prepay discount** to be applicable.
- Delivery – 27 - 31 months from receipt and acceptance of contract.



MINNESOTA ILLINOIS INDIANA MISSOURI NEBRASKA NORTH DAKOTA SOUTH DAKOTA

Said apparatus and equipment are to be built and shipped in accordance with the specifications hereto attached, delays due to strikes, war, or international conflicts, or other causes beyond our control not preventing, could alter the delivery schedule.

The specifications herein contained, shall form a part of the final contract, and are subject to changes as desired by the purchaser, provided such changes are acknowledged and agreed to in writing by the purchaser.

This proposal for fire apparatus conforms with all Federal Department of Transportation (DOT) rules and regulations in effect at the time of bid, and with all National Fire Protection Association (NFPA) Guidelines for Automotive Fire Apparatus as published at the time of bid, except as modified by customer specifications.

The attached proposal is valid for thirty (30) days.

We trust the above and the enclosed to be full and complete at this time; however, should you have any questions or require additional information, please do not hesitate to contact me at 507-272-2360 or tom.soland@macqueengroup.com.

We wish to thank the City of Marshall Fire Department for the opportunity to submit our proposal.

Respectfully,

Tom Soland

Tom Soland
Apparatus Sales
MacQueen Equipment LLC
DBA MacQueen Emergency Group

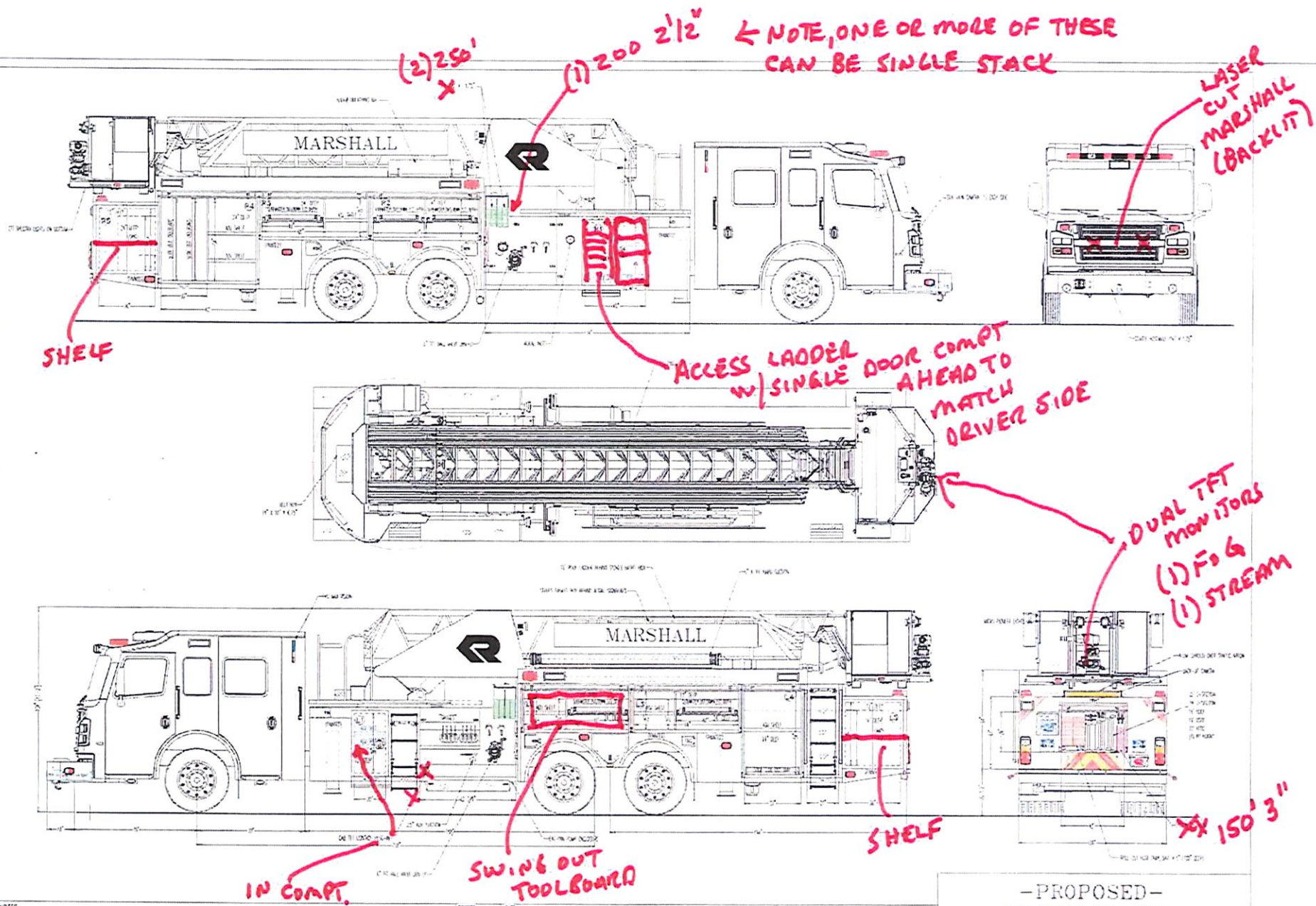

NOTES:
 1. OVERALL HEIGHT IS IN LOADED CONDITION. UNLOADED HEIGHTS MAY BE AT ABOVE HEIGHTS SHOWN.
 2. DO NOT SCALE DRAWING.
 3. ALL DIMENSIONS ARE APPROXIMATE AND SUBJECT TO ENGINEERING CHANGES.
 4. DRAWING MAY OR MAY NOT SHOW ALL ITEMS AS DESCRIBED IN THE WRITTEN DETAIL SPECIFICATIONS.
 5. INCLUSION OF AN ITEM ON THE DRAWING DOES NOT CONSTITUTE INCLUSION OF THAT ITEM WITH THE FINAL DELIVERED UNIT.

PROPRIETARY AND CONFIDENTIAL
 THE INFORMATION CONTAINED IN THIS DRAWING IS THE SOLE PROPERTY OF ROSENBAUER. ANY REPRODUCTION IN PART OR AS A WHOLE WITHOUT THE WRITTEN PERMISSION OF ROSENBAUER IS PROHIBITED.

APPROVED BY:	CHASSIS: ROSENBAUER R7011
MAXIMUM HEIGHT: NONE	PUMP: WATERBUS 5100 2000 GPM
MAXIMUM LENGTH: NONE	TANK: POLY 480 / 20 GAL
BODY WIDTH: 100"	TYPE: PUMPLER
	AERIAL: 100' MIDMOUNT PLATFORM

- PROPOSED -
 MARSHALL, MN.

ROSENBAUER EXT
 PR511 01

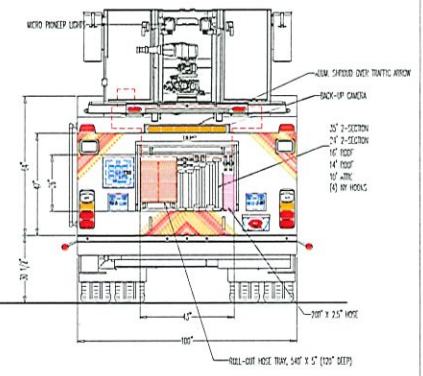
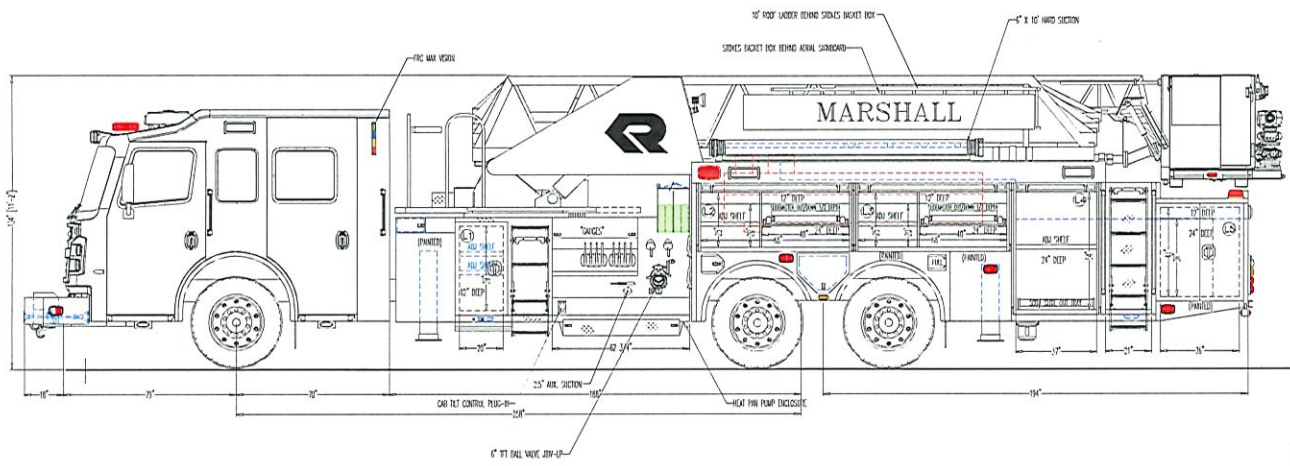
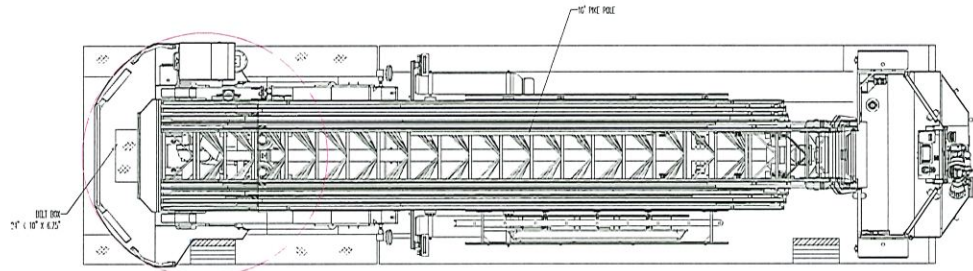
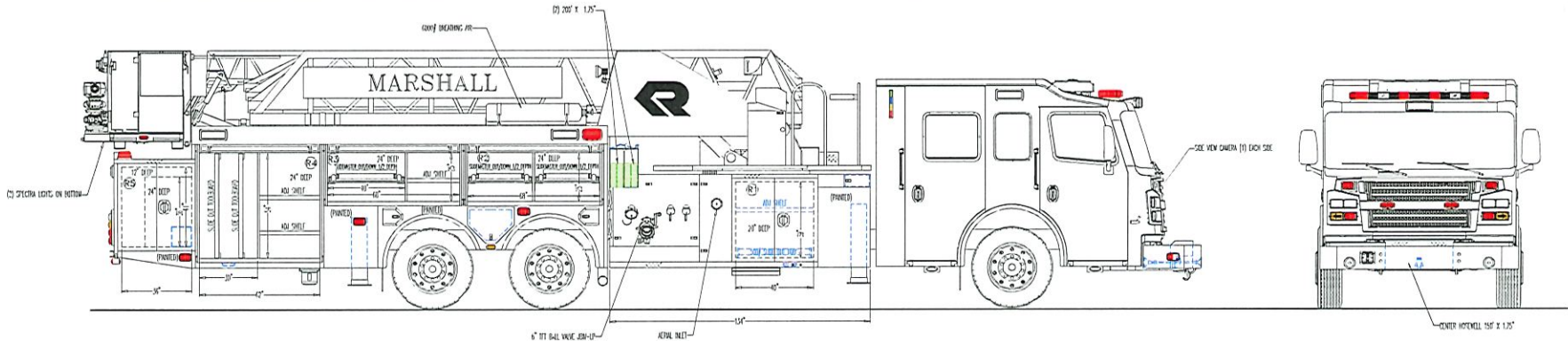

- NOTES:
1. OVERALL HEIGHT IS IN LOADED CONDITION. UNLOADED HEIGHTS MAY BE 4" ABOVE HEIGHTS SHOWN.
 2. DO NOT SCALE DRAWING.
 3. ALL DIMENSIONS ARE APPROXIMATE AND SUBJECT TO ENGINEERING CHANGES.
 4. DRAWING MAY OR MAY NOT SHOW ALL ITEMS AS DESCRIBED IN THE WRITTEN DETAIL SPECIFICATIONS.
 5. INCLUSION OF AN ITEM ON THE DRAWING DOES NOT CONSTITUTE INCLUSION OF THAT ITEM WITH THE FINAL DELIVERED UNIT.

REVISED: - DATE: -
 APPROVED: - DATE: -
 DRAWN: JMY DATE: 07-18-2022 (PST/CA-TZ)
 PROPRIETARY AND CONFIDENTIAL
 THE INFORMATION CONTAINED IN THIS DRAWING IS
 THE SOLE PROPERTY OF ROSENBAUER. ANY
 REPRODUCTION IN PART OR AS A WHOLE WITHOUT
 THE WRITTEN PERMISSION OF ROSENBAUER IS
 PROHIBITED.

APPROVED BY:

MAXIMUM HEIGHT	NONE
MAXIMUM LENGTH	NONE
BODY WIDTH	100"

CHASSIS:	ROSENBAUER R7011
PUMP:	WATEROUS S100 2000 GPM
TANK:	POLY 480 / 20 GAL.
TYPE:	PUMPER
AERIAL:	100' MIDMOUNT PL-TFORM

-PROPOSED-
 MARSHALL, MN.



ROSENBAUER EXT
 P8544 01



PURCHASE ORDER

Purchaser		SUPPLIER	
Purchaser:	City of Marshall	Contract #	FS12-19 For Years 2019-2023
Address 1:	344 West Main Street	Supplier:	Rosenbauer Minnesota, LLC
Address 2:		Address 1:	5180 260th Street
City, State, Zip:	Marshall, MN 56258	Address 2:	PO Box 549
		City, State, Zip:	Wyoming, MN 55092

Purchase Order Number:		Delivery in Calendar Days:	600
Date:	9/7/2022	HGAC Product Code	FS19YA08

The amount in this proposal shall remain firm for a period of 30 days from the date of same.

Quantity	Description	Price	Price (Extended)
1	One (1) Rosenbauer Aerial, complete with Rosenbauer Commander chassis and Rosenbauer Cobra Platform per attached specifications.	\$1,470,838.00	\$1,470,838.00
	Note: HGAC administration fee included in price		
	*Note: If chassis amount of \$444,695.00 is paid upon arrival at our plant in Minnesota, deduct \$17,075.00 each		
	*Note: If aerial amount of \$451,664.00 is paid upon arrival at our plant in Minnesota, deduct \$8,802.00 each		
	TOTAL		\$1,470,838.00

NOTES:	
--------	--

Rosenbauer Dealer :	General Safety Fire Apparatus
Salesperson:	Steve Harris
Signature:	

Purchaser:	City of Marshall
Print Name:	
Title:	
Date:	
Signature:	

Item 9.



APPENDIX C
CHANGE ORDER POLICY

This change order policy is intended to reflect the increased cost of changes which result in delayed deliveries, confused paperwork, poor production flow and increased potential of trucks being built to incorrect specifications. With your cooperation, changes can be kept to a minimum which means we will be able to reduce lead times, increase production and maintain costs which will benefit all of us.

Our objective is accurate, high quality and on-time deliveries exceeding our customer expectations.

Changes any time after the order is received may delay the quoted delivery date. Significant design or component changes will have the largest impact on the schedule and quoted delivery date. Changes that occur later in the process will also have the largest impact on the schedule and quoted delivery date.

All time fences are reference to contract execution date if not otherwise stated.

Change Window #1

All changes will be priced at standard pricing and specials will be priced through our normal process. Significant changes made to the vehicle during this time period may result in a delivery extension.

RBM Chassis	0-60 days
RBA Aerial	0-60 days
Rosenbauer Body	0-60 days

Change Window #2

All changes are subject to a 25% mark-up, as well as a \$250.00 change order processing fee. All changes are subject to factory review and may be denied due to engineering or lead time issues.

RBM Chassis	61-75 days
RBA Aerial	61-75 days
Rosenbauer Body	61-120 days

Change Window #3

All changes are subject to a 50% mark-up, and 50% restocking fee on deleted items, as well as a \$250.00 change order processing fee. All changes are subject to factory review and may be denied due to engineering or lead time issues. No major components can be changed at this time; major components are considered engine, transmission, axles, suspension, cab, frame (wheelbase), seats, water pump and water tank.

RBM Chassis	76-120 days
RBA Aerial	76-120 days
Rosenbauer Body	121-180 days

Change Window #4

Changes are not recommended at this time. Any changes requested will be priced on a time and material basis, as well as a \$500.00 change order processing fee. Any changes requested, and that are quoted to the customer, must be approved by the customer within three days or they will not be valid.

RBM Chassis	After 120 days
RBA Aerial	After 120 days
Rosenbauer Body	After 180 days

**Note: Any late change orders that are factory driven will be done at cost and no additional mark up or penalties will apply.*

BUYER INITIALS: _____

RESOLUTION NO. 22-085

CITY OF MARSHALL, MINNESOTA

DECLARING THE OFFICIAL INTENT OF THE CITY OF MARSHALL, MINNESOTA TO REIMBURSE CERTAIN EXPENDITURES FROM THE PROCEEDS OF TAX-EXEMPT BONDS OR OTHER OBLIGATIONS TO BE ISSUED BY THE CITY

WHEREAS, the Internal Revenue Service has issued Treas. Reg. § 1.150-2 (the “Reimbursement Regulations”) providing that proceeds of tax-exempt obligations used to reimburse prior expenditures will not be deemed spent unless certain requirements are met; and

WHEREAS, the City of Marshall, Minnesota (the “City”) expects to incur certain expenditures that may be financed temporarily from sources other than tax-exempt bonds and other obligations, and reimbursed from the proceeds of tax-exempt obligations; and

WHEREAS, the City has determined to make this declaration of official intent (the “Declaration”) to reimburse certain costs from proceeds of tax-exempt bonds or other obligations in accordance with the Reimbursement Regulations; and

NOW, THEREFORE, BE IT RESOLVED BY THE CITY COUNCIL OF THE CITY OF MARSHALL, MINNESOTA AS FOLLOWS:

1. The City proposes to acquire a fire truck and other related equipment (collectively, the “Project”).

2. The City reasonably expects to reimburse the expenditures made for certain costs of the Project from the proceeds of tax-exempt bonds or other obligations in an estimated maximum principal amount of \$1,800,000. All reimbursed expenditures will be capital expenditures, costs of issuance of the bonds or other obligations, or other expenditures eligible for reimbursement under Section 1.150-2(d)(3) of the Reimbursement Regulations.

3. This Declaration has been made not later than sixty (60) days after payment of any original expenditure to be subject to a reimbursement allocation with respect to the proceeds of tax-exempt bonds or other obligations, except for the following expenditures: (a) costs of issuance of bonds or other obligations; (b) costs in an amount not in excess of \$100,000 or five percent (5%) of the proceeds of an issue of bonds or other obligations; or (c) “preliminary expenditures” up to an amount not in excess of twenty percent (20%) of the aggregate issue price of the issue or issues that finance or are reasonably expected by the City to finance the project for which the preliminary expenditures were incurred. The term “preliminary expenditures” includes architectural, engineering, surveying, soil testing, bond issuance, and similar costs that are incurred prior to commencement of acquisition, construction or rehabilitation of a project, other than land acquisition, site preparation, and similar costs incident to commencement of construction.

4. This Declaration is an expression of the reasonable expectations of the City based on the facts and circumstances known to the City as of the date hereof. The anticipated original expenditures for the Project and the principal amount of the tax-exempt bonds or other obligations described in paragraph 2 are consistent with the City’s budgetary and financial circumstances. No sources other than proceeds of tax-exempt bonds or other obligations to be issued by the City are, or are reasonably expected to be, reserved, allocated on a long-term basis, or otherwise set aside pursuant to the City’s budget or financial

policies to pay such Project expenditures.

5. This Declaration is intended to constitute a declaration of official intent for purposes of the Reimbursement Regulations.

Approved this 25th day of October, 2022, by the City Council of the City of Marshall, Minnesota.

Robert J. Byrnes, Mayor

Attest:

Steven Anderson, City Clerk

**CITY OF MARSHALL
AGENDA ITEM REPORT**

Presenter:	Quentin Brunsvold
Meeting Date:	Tuesday, October 25, 2022
Category:	CONSENT AGENDA
Type:	INFO/ACTION
Subject:	Council approval to apply for the 2023 FEMA Assistance to Fire Fighters Grant.
Background Information:	The Marshall Fire Department is requesting approval to apply for two FEMA AFGs (Assistance to Fire Fighters Grants). One to replace the fire department’s portable and mobile radio systems. The other to purchase an Aerial Apparatus. The cost of the radio systems could be up to \$250,000. The cost of the Aerial Apparatus is \$1,470,838. There is a 10% match by the requesting municipality which will be paid for with the general fund levy.
Fiscal Impact:	Upfront cost for grant writing \$1,250 and 10% match if grant is awarded to the City of Marshall.
Alternative/ Variations:	None
Recommendations:	Consider approval to apply for the 2023 FEMA AFG Grant.



INVOICE

803

Date: Sep 29, 2022

Payment Terms: due on receipt

Karin Anderson Grantwriting
Po Box 1C, Farwell MN 56327

Balance Due: \$1,250.00

Bill To:

Marshall Fire Department
Marshall, MN

Item	Quantity	Rate	Amount
Fema grant 2022 for Radios	1	\$450.00	\$450.00
Fema grant 2022 for Aerial Truck	1	\$800.00	\$800.00

Subtotal: \$1,250.00

Tax (0%): \$0.00

Total: \$1,250.00

Notes:

Grant fees to be paid up front and include ALL closeout reports.

**CITY OF MARSHALL
AGENDA ITEM REPORT**

Presenter:	Sheila Dubs
Meeting Date:	Tuesday, October 25, 2022
Category:	NEW BUSINESS
Type:	ACTION
Subject:	Health and Dental Insurance renewals for 2023
Background Information:	<p>Bill Chukuske (National Insurance Services) is our broker for health and dental insurances. At this meeting, Bill will present the 2023 renewal information and Staff will present the employee-employer cost-share options.</p> <p>A history of the City’s premium renewals, a review of the claims data, and review of health and dental comparable-city information was previously provided and presented at the Council worksession on October 11, 2022.</p> <p>Health Insurance Renewal: For 2022-2023, the Council approved a 2-year commitment with BCBS---resulting in a 12% decrease in premiums compared to the rates offered by PEIP for 2022. The agreement with BCBS included a maximum rate cap in the 2nd year (2023) of 11%. Bill negotiated a reduced rate increase of 8.8% for 2023.</p> <p>Dental Insurance renewal: For 2022-2023, the Council approved a 2-year commitment with Delta Dental, with a 0% increase in premium rates for 2023.</p> <p>Staff recommend Council approval of Option A---the City and Employees share equally in the health insurance premium increase, each increasing 8.8% and maintaining an 80/20% employer-employee cost-share for dental insurance. The cost projections are based on current plan selection by employees.</p>
Fiscal Impact:	<p>Estimated health insurance premium increase of \$104,100.96.</p> <p>The dental renewal reflected a 0% increase in premiums. The estimated dental premium increase is \$0.00.</p>
Alternative/ Variations:	To approve the alternative cost-share Option B: the City and Employees share equally in the health insurance premium increase, each increasing 8.8%, and a 75/25% employer-employee cost-share of the premium for dental insurance.
Recommendations:	To approve the 2023 health and dental renewals at cost-share Option A.

National Insurance Services

City of Marshall Benefits Recap for 2023

Medical:

August 2021 conducted RFP (request for proposal) effective January 1, 2022

- Reduction in rates from PEIP to BCBS by 12%
- Second year rate cap of 11% (Not to Exceed)
 - Renewal formulary for 2023 calculated **17.8%**
 - Based on 8 months of claims and Manual Rate
 - Renewal Cap **11.0%**
 - Negotiated increase for 2023 **8.8%**
- Two-year savings from 2021 **15.7%**
 - \$516,622.00 (based on PEIP renewal numbers)

Renewals and rates past six years:

- 2018 Coop \$692.50/\$1852.00 7.1% Increase
- 2019 Coop \$638.50/\$1698.50 12.3% Increase
- 2020 PEIP \$673.82/\$1782.36 6.3% Increase
- 2021 PEIP \$718.32/\$1901.10 6.6% Increase
- 2022 BCBS \$632.33/\$1673.51 11.9% Decrease
- 2023 BCBS \$687.98/\$1820.78 8.8% Increase
 - 4.22% less than 2021

Dental:

- 2019 \$45.22/\$125.64
- 2020 \$46.12/\$128.16 1.9% Increase
- 2021 \$46.12/\$128.16 0.0% Increase
- 2022 \$47.96/\$133.28 3.9% Increase
- 2023 \$47.96/\$133.28 0.0% Increase

Renewal Package for

City of Marshall

283978

from Blue Cross and Blue Shield of Minnesota

Effective Date : January 1, 2023



*This renewal and all attachments are confidential
Quote date 08/03/2022*

City of Marshall

Projected Renewal Year Claims

Coverage Effective Date: 01/01/2023

	(Most Recent)	
	<u>Rating Period 1</u>	<u>Rating Period 2</u>
Total incurred claims	\$376,788	\$1,338,536
Remove Claims Above Pooling Level (at \$85,000)	(\$39,731)	\$0
Projection Year Adjustments*	\$22,127	(\$55,978)
Total Completed Claims	\$359,184	\$1,282,558
Cost Trend Factor	11.6%	19.6%
01/2022 - 06/2022: 15 months at 0.73% per month (9.1% annual trend)		
01/2021 - 12/2021: 24 months at 0.75% per month (9.4% annual trend)		
Trended Claims	\$400,984	\$1,533,940
Pooling Charge	\$226,023	\$450,315
Projected Renewal Year Claims	\$627,007	\$1,984,255
Member Months	1,697	3,381
PMPM	\$369.48	\$586.88
Weight	67%	33%
Weighted Projected Renewal Year Claims (PMPM)	\$246.63	\$195.13

*Includes IBNR, settlements, withholds, benefit adjustments and other adjustments based on expectations of projected year experience.

Renewal Development Summary

Coverage Effective Date: 01/01/2023

	Period PMPM	Period Weight	Adjusted PMPM
Weighted Experience Claims Projection			
Period 1 weighted projected renewal year claims	\$369.48	66.8%	\$246.63
Period 2 weighted projected renewal year claims	\$586.88	33.2%	\$195.13
Total projected renewal year claims			\$441.76
Manual Incurred Claims Projection (Experience to Manual: 0.808)	\$546.63		
Credibility Weighted Claims			
50% applied to weighted experience claims projection	\$220.88		
50% applied to manual claims projection	\$273.31		\$494.20

Administrative Expenses

General Administrative Expense	\$17.10	
MN Taxes/Assessments	\$5.40	
ACA Taxes/Assessments	\$0.27	
Contribution to Reserves	\$23.23	
Network Access Fee (No additional fee)	\$0.00	
Agent Commission	\$8.10	\$54.11
Total Administrative Expense: 10.0%		

Total Projected Renewal Year Premiums

	Member Counts	
\$2000 non-embedded H S A, Classic Rx, Key Rx,Aware	283	
Needed Income, with commission, if applicable		\$548.30
Current Income, with commission, if applicable		\$465.47
Total Needed Income, with commission, if applicable - All Plans		\$1,862,038
Total Current Income, with commission, if applicable		\$1,580,729

Calculated change in rates	17.8%
Recommended change in rates, effective 01/01/2023	11.0%



Rating Period High Claimants Report

Coverage Effective Date: 01/01/2023

Members Exceeding \$61,000 for Period 1		Total Dollars
Case 1	Active	\$100,731

Members Exceeding \$85,000 for Period 2		Total Dollars
There were no cases that exceeded this limit		

Active: At the time of the report, the member is receiving benefits through the group's health plan.

Inactive: At the time of the report, the member is no longer receiving benefits through the group's health plan.



Renewal Rates

Coverage Effective Date: 01/01/2023

Renewal Months 12

Min Value

			Current Rates	Renewal Rates	Change in Rates
PLAN 1	\$2000 non-embedded H S A, Classic Rx, Key Rx,Aware				
	Single	31	\$632.33	\$701.89	
	Family	67	\$1,673.51	\$1,857.60	
		Annual Total Premium	\$1,580,729	\$1,754,609	
	Group Total	98	\$1,580,729	\$1,754,609	11.0%

- Rates include 1.5% commission

Renewal Rates

Coverage Effective Date: 01/01/2023

Renewal Months 12

Min Value

			Current Rates	Renewal Rates	Change in Rates
PLAN 1	\$2000 non-embedded H S A, Classic Rx, Key Rx,Aware				
	Single	31	\$632.33	\$687.98	
	Family	67	\$1,673.51	\$1,820.78	
		Annual Total Premium	\$1,580,729	\$1,719,833	
Group Total	98		\$1,580,729	\$1,719,833	8.8%

- Rates include 1.5% commission

City of Marshall
\$2,000 Non-embedded H SA
1/1/2023

Coinsurance reflects member responsibility

	In network* MN Network: Aware National Network: Blue Card PPO	Out of network**
Calendar-year deductible The in- and out-of-network maximums cross apply. No fourth quarter carryover	Medical and prescription combined \$2,000 individual \$4,000 family	Medical and prescription combined \$4,000 individual \$8,000 family
Coinsurance Level – What the member pays	Deductible then 25% coinsurance	Deductible then 50% coinsurance
Calendar-year out-of-pocket maximum The in- and out-of-pocket maximums cross apply. Non-covered charges and charges in excess of the allowed amount do not apply to the out-of-pocket maximum.	Medical and prescription combined \$3,000 individual \$6,000 family	Medical and prescription combined \$6,000 individual \$12,000 family
Benefit payment levels	Payment for participating network providers as described. Most payments are based on allowed amount.	If nonparticipating provider services are covered, you are responsible for the difference between the billed charges and allowed amount. Most payments are based on allowed amount.
Preventive care <ul style="list-style-type: none"> well-child care to age 6 prenatal care preventive medical evaluations age 6 and older cancer screening preventive hearing and vision exams immunizations and vaccinations 	0% 0% 0% 0% 0% 0%	0% 0% Deductible then 50% coinsurance Deductible then 50% coinsurance Deductible then 50% coinsurance Deductible then 50% coinsurance
Omada® diabetes and cardiovascular disease prevention program (Generic Program)	0%	No coverage
Physician services <ul style="list-style-type: none"> e-visits retail health clinic (office visit) physician office visit office and outpatient lab diagnostic imaging allergy injections and serum specialist office visits specialist office and outpatient lab services Urgent Care professional services 	Deductible then 25% coinsurance Deductible then 25% coinsurance Deductible then 25% coinsurance Deductible then 25% coinsurance Deductible then 25% coinsurance Deductible then 25% coinsurance Deductible then 25% coinsurance Deductible then 25% coinsurance	Deductible then 50% coinsurance Deductible then 50% coinsurance Deductible then 50% coinsurance Deductible then 50% coinsurance Deductible then 50% coinsurance Deductible then 50% coinsurance Deductible then 50% coinsurance Deductible then 50% coinsurance
Other professional services <ul style="list-style-type: none"> chiropractic manipulation (office visit) chiropractic therapy home health care physical therapy, occupational therapy, speech therapy (office visit) physical therapy, occupational therapy, speech therapy (therapy) 	Deductible then 25% coinsurance Deductible then 25% coinsurance Deductible then 25% coinsurance Deductible then 25% coinsurance Deductible then 25% coinsurance	Deductible then 50% coinsurance Deductible then 50% coinsurance Deductible then 50% coinsurance Deductible then 50% coinsurance Deductible then 50% coinsurance
Hospital Inpatient services	Deductible then 25% coinsurance	Deductible then 50% coinsurance
Hospital outpatient services <ul style="list-style-type: none"> facility lab services facility diagnostic imaging chemotherapy and radiation therapy scheduled outpatient surgery urgent care services (facility services) 	Deductible then 25% coinsurance Deductible then 25% coinsurance Deductible then 25% coinsurance Deductible then 25% coinsurance Deductible then 25% coinsurance	Deductible then 50% coinsurance Deductible then 50% coinsurance Deductible then 50% coinsurance Deductible then 50% coinsurance Deductible then 50% coinsurance

	In network* MN Network: Aware National Network: Blue Card PPO	Out of network**
Emergency care • emergency room (facility charges) • professional charges • ambulance (medically necessary transport to the nearest facility equipped to treat the condition)		Deductible then 25% coinsurance Deductible then 25% coinsurance Deductible then 25% coinsurance
Durable Medical Equipment	Deductible then 25% coinsurance	Deductible then 50% coinsurance
Bariatric surgery	Deductible then 25% coinsurance	No coverage
Assisted fertilization	No coverage	No coverage
Behavioral health (mental health and substance abuse services) • inpatient professional services • outpatient professional services (office visits) • outpatient hospital/facility services	Deductible then 25% coinsurance Deductible then 25% coinsurance Deductible then 25% coinsurance	Deductible then 50% coinsurance Deductible then 50% coinsurance Deductible then 50% coinsurance
Prescription drugs – Classic Network • retail (31-day limit) KeyRx drug list • Tier 1 – Preferred generics • Tier 2 – Non-preferred generics • Tier 3 – Preferred brands • Tier 4 – Non-preferred brands Specialty drug list • Tier 1 • Tier 2 • Tier 3 • Tier 4 • 90dayRx – Mail order/Retail pharmacy (90-day limit) KeyRx drug list • Tier 1 – Preferred generics • Tier 2 – Non-preferred generics • Tier 3 – Preferred brands • Tier 4 – Non-preferred brands	Deductible then 25% coinsurance Deductible then 25% coinsurance Deductible then 25% coinsurance Deductible then 25% coinsurance Deductible then 25% coinsurance Deductible then 25% coinsurance Deductible then 25% coinsurance Deductible then 25% coinsurance Deductible then 25% coinsurance Deductible then 25% coinsurance Deductible then 25% coinsurance	No coverage No coverage No coverage No coverage No coverage No coverage No coverage No coverage No coverage No coverage No coverage No coverage
	90dayRx applies to participating retail and/or mail service pharmacy only. Identified specialty drugs purchased through a specialty pharmacy network supplier are eligible for coverage (no coverage for specialty drugs purchased through a nonparticipating specialty pharmacy supplier). The patient will pay the difference if a brand-name drug is dispensed when a generic drug is available. The drug list uses a step therapy program. Sign in at bluecrossmnonline.com and select "Prescriptions," then see "frequently asked questions."	

Your out-of-pocket costs depend on the network status of your provider. To check status, call Blue Cross customer service or visit bluecrossmnonline.com.

***Lowest out-of-pocket costs:** in-network providers

Highest out-of-pocket costs: out-of-network **nonparticipating** providers (You are responsible for the difference between Blue Cross' allowed amount and the amount billed by nonparticipating providers. This is in addition to any applicable deductible, copay or coinsurance. Benefit payments are calculated on Blue Cross' allowed amount, which is typically lower than the amount billed by the provider.)

This plan is Medicare Part D creditable.

Non-embedded deductible – The plan begins paying benefits that require cost sharing when the entire family deductible is met. The deductible can be met by one or a combination of several family members. The individual deductible applies to single coverage only.

This is only a summary. Read your benefit booklet for more information about what is and isn't covered. Services that aren't covered include those that are cosmetic, investigative, not medically necessary or covered by workers' compensation or no-fault insurance.

For more information, visit bluecrossmnonline.com or call Blue Cross customer service at the number on the back of your member ID card.

The Omada program is from Omada Health, Inc., an independent company providing digital care programs.

Blue Cross® and Blue Shield® of Minnesota and Blue Plus® are nonprofit independent licenses of the Blue Cross and Blue Shield Association



**REVISED RENEWAL CALCULATION
24 MONTH CONTRACT**

Group Name: City of Marshall
 Group Number: 310748
 Renewal Period: January 1, 2022 through December 31, 2023
 Experience Period: June 1, 2020 through May 31, 2021

Earned Premium: \$130,419
 Incurred Claims: \$91,651
 Estimated Unpaid Claim Liability*: \$23
 * EUCL has already been added to the incurred claim total

Average Experience Period Enrollment:	Single	31
	Family	74
	Total	<hr/> 105

Trend Factor: 5.60%
 Trend is calculated from the mid-point of the experience period to the midpoint of the renewal period.

Current Corporate Trend: 3.50%

Benefit Adjustment Factor (BAF): 0.00%
 BAF is needed if any benefit changes are proposed for the upcoming contract period.

Covid Factor: 19.64%
 Calculated for each group individually based on pre-Covid usage

Projected Incurred Claims: \$115,792

Needed Increase: 14.90%
 Proposed Increase: 4.00%

Rates:		Current Rates	New Rates
	Single	\$46.12	\$47.96
	Family	\$128.16	\$133.28

Revised Renewal reflects decreasing the rates, effective January 1, 2022.

Delta Dental reserves the right to re-evaluate the rates/fees and restrict funding options if during the contract period:

- * the number of enrolled employees deviates from the above enrollment by 10% or more
- * any changes are made to the plan design, contractual benefits or networks that are utilized

This renewal is valid only if the contract is issued in the state of Minnesota.

Note: Our rates include all applicable taxes and fees. 78.64% Target Loss Ratio CRB
2.00% Broker Commission 9/13/21

Enrollment and Paid Claims
 City of Marshall
 310748



Delta Dental of Minnesota

MONTHS	CLAIMS*	PAID CLAIMS	% OF PAID CLAIMS	ADMIN/ PREMIUM	SUBSCRIBER	SUBSCRIBER AND SPOUSE	SUBSCRIBER AND CHILD	SUBSCRIBER AND CHILDREN	SUBSCRIBER, SPOUSE, CHILD(REN)	TOTAL SUBSCRIBERS
JUL-2021	50	\$7,815.44	7.26%	\$10,913.56	33	18	0	2	54	107
AUG-2021	57	\$9,916.30	9.21%	\$11,041.72	33	18	0	2	54	107
SEP-2021	61	\$10,303.96	9.57%	\$10,959.68	33	18	0	2	54	107
OCT-2021	39	\$8,262.80	7.67%	\$10,959.68	33	19	0	2	53	107
NOV-2021	39	\$6,524.05	6.06%	\$10,959.68	34	19	0	2	53	108
DEC-2021	56	\$10,422.93	9.68%	\$11,005.80	33	18	0	2	53	106
JAN-2022	40	\$5,301.11	4.92%	\$12,718.28	28	17	0	2	57	104
FEB-2022	46	\$9,011.34	8.37%	\$9,783.36	29	17	0	2	57	105
MAR-2022	55	\$10,206.67	9.48%	\$11,738.72	30	17	0	2	57	106
APR-2022	46	\$8,708.25	8.09%	\$11,568.08	30	17	0	2	58	107
MAY-2022	32	\$5,934.50	5.51%	\$11,520.12	33	16	0	2	58	109
JUN-2022	72	\$15,261.95	14.17%	\$11,807.88	33	16	0	2	58	109
TOTAL	593	\$107,669.30	100.0%	\$134,976.56						
AVERAGE	49	\$8,972.44	100.0%	\$11,248.05	32	18	0	2	56	107

*Adjusted claims can be counted in more than one month

Payment by Service Category: By Member Type
 City of Marshall
 310748



Delta Dental of Minnesota

SERVICE CATEGORY	CURRENT PERIOD (07-01-2021 to 06-30-2022)					DDMN	PRIOR PERIOD (07-01-2020 to 06-30-2021)			
	Subscriber	Spouse	Child	ALL			Subscriber	Spouse	Child	ALL
	CLAIMS PAID	CLAIMS PAID	CLAIMS PAID	TOTAL CLAIMS PAID	% OF TOTAL	AVG % OF TOTAL	CLAIMS PAID	CLAIMS PAID	CLAIMS PAID	TOTAL CLAIMS PAID
Diagnostic & Preventive	\$24,425	\$16,617	\$29,564	\$70,605	65.58%	46.97%	\$19,500	\$13,827	\$24,408	\$57,735
Cleanings	\$11,687	\$7,600	\$11,084	\$30,372	28.21%	19.34%	\$9,180	\$6,547	\$9,497	\$25,224
Exams	\$6,408	\$4,846	\$8,405	\$19,659	18.26%	12.87%	\$5,715	\$4,281	\$7,578	\$17,573
Sealants	\$0	\$0	\$1,943	\$1,943	1.80%	0.96%	\$0	\$0	\$1,562	\$1,562
Basic Restorative	\$2,648	\$2,610	\$3,690	\$8,947	8.31%	12.47%	\$3,748	\$1,901	\$3,538	\$9,188
Endodontics	\$2,758	\$732	\$397	\$3,887	3.61%	4.36%	\$1,880	\$0	\$0	\$1,880
Periodontics	\$412	\$0	\$0	\$412	0.38%	2.47%	\$1,971	\$164	\$0	\$2,135
Oral Surgery	\$734	\$1,124	\$3,011	\$4,869	4.52%	7.08%	\$1,054	\$1,436	\$472	\$2,963
Oral Surgery - Surgical	\$631	\$1,124	\$1,664	\$3,419	3.18%	4.66%	\$638	\$821	\$0	\$1,459
Oral Surgery - Simple	\$103	\$0	\$1,347	\$1,450	1.35%	1.75%	\$416	\$318	\$472	\$1,206
Major Restorative	\$5,174	\$2,388	\$632	\$8,194	7.61%	11.54%	\$4,546	\$2,815	\$0	\$7,361
Prosthodontics	\$1,571	\$930	\$797	\$3,298	3.06%	5.57%	\$1,290	\$1,978	\$0	\$3,268
Bridges	\$0	\$0	\$0	\$0	0.00%	0.92%	\$781	\$0	\$0	\$781
Dentures	\$0	\$0	\$0	\$0	0.00%	1.95%	\$509	\$0	\$0	\$509
Implants	\$1,571	\$930	\$797	\$3,298	3.06%	2.51%	\$0	\$1,978	\$0	\$1,978
Orthodontics	\$0	\$0	\$5,920	\$5,920	5.50%	7.53%	\$0	\$0	\$4,469	\$4,469
Adjunctive General	\$717	\$0	\$820	\$1,537	1.43%	2.01%	\$324	\$285	\$50	\$659
TOTAL	\$38,438	\$24,401	\$44,830	\$107,669	100.00%	100.00%	\$34,312	\$22,406	\$32,937	\$89,655

City of Marshall

Group #310748

Plan Benefit Highlights			
Network(s)	Delta Dental PPO SM	Delta Dental Premier [®]	Non-Participating*
Calendar Year Plan Maximum Per person	\$1,000	\$1,000	\$1,000
Lifetime Ortho Maximum <i>Per eligible covered person</i>	\$1,000	\$1,000	\$1,000
Deductible Per person / per family per Calendar year <i>No deductible for diagnostic and preventive services or orthodontics</i>	\$50/person \$150/family	\$50/person \$150/family	\$50/person \$150/family
Eligible Dependents	Spouse Dependent children up to age 26		
Covered Services	Dental Benefit Plan Coverage		
Diagnostic & Preventive Services Exams Cleanings X-rays Fluoride treatments Space maintainers Sealants	100%	100%	100%
Basic Services Emergency treatment for relief of pain Amalgam restorations (silver fillings) Composite resin restorations (white fillings) on anterior (front) teeth	80%	80%	80%
Endodontics Root canal therapy on permanent teeth Pulpotomies on primary teeth for dependent children	80%	80%	80%
Periodontics Surgical/Nonsurgical periodontics	80%	80%	80%
Oral Surgery Surgical/Nonsurgical extractions All other covered oral surgery	80%	80%	80%
Major Restorative Crowns Composite resin restorations (white fillings) on posterior (back) teeth	50%	50%	50%
Prosthetic Repairs and Adjustments Denture adjustments and repairs Bridge repair	50%	50%	50%
Prosthetics Dentures (full and partial) Bridges Limited Implant Coverage	50%	50%	50%
Orthodontics Treatment for the prevention/ correction of malocclusion <i>Available for dependent children only, through the age 18</i>	50%	50%	50%

This is a summary of benefits only and does not guarantee coverage. For a complete list of covered services and limitations/exclusions, please refer to the Dental Benefit Plan Summary.

*Dentists who have signed a participating network agreement with Delta Dental have agreed to accept the maximum allowable fee as payment in full. Non-participating dentists have not signed an agreement and are not obligated to limit the amount they charge; the member is responsible for paying any difference to the non-participating dentists.

**2022 Comparable Cities Survey--Health and Dental
Combined Employer Contribution
SINGLE PLANS**

TOTAL EMPLOYER CONTRIBUTION Rank High to Low			Deductible	Monthly Premium	Monthly Employer Contribution	Monthly Employer Contribution %	Monthly Employee Contribution	Annual VEBA/HSA Employer Contribution	Total Annual Employer Contribution	TOTAL COMBINED EMPLOYER CONTRIBUTION
SINGLE									SINGLE	SINGLE
1	Waseca	Medical	4000/6400	\$ 755.94	\$ 755.94	100.00%	\$ -	\$ 4,254.00	\$ 13,325.28	\$ 13,325.28
		Dental		\$ 29.58	\$ -	0.00%	\$ 29.58		\$ -	
2	St Peter	Medical	1850	\$ 862.50	\$ 862.50	100.00%	\$ -	\$ 1,200.00	\$ 11,550.00	\$ 11,964.48
		Dental		\$ 34.54	\$ 34.54	100.00%	\$ -		\$ 414.48	
3	Albert Lea	Medical	3250/6500	\$ 856.96	\$ 753.96	87.98%	\$ 103.00	\$ 1,200.00	\$ 10,247.52	\$ 10,247.52
		Dental		\$ 30.20	\$ -	0.00%	\$ 30.20		\$ -	
4	Fairmont	Medical	5000/1000	\$ 780.71	\$ 780.71	100.00%	\$ -	\$ 500.00	\$ 9,868.52	\$ 10,168.52
		Dental		\$ 25.00	\$ 25.00	100.00%	\$ -		\$ 300.00	
5	Willmar	Medical	2000/3000	\$ 581.93	\$ 579.22	99.53%	\$ 2.71	\$ 3,000.00	\$ 9,950.64	\$ 9,950.64
		Dental		\$ 31.01	\$ -	0.00%	\$ 31.01		\$ -	
6	Northfield	Medical	3000/6000	\$ 685.68	\$ 655.34	95.58%	\$ 30.34	\$ 1,750.00	\$ 9,614.08	\$ 9,808.48
		Dental		\$ 32.00	\$ 16.20	50.63%	\$ 15.80		\$ 194.40	
7	Worthington	Medical	2000/4000	\$ 675.74	\$ 675.74	100.00%	\$ -	\$ 750.00	\$ 8,858.88	\$ 9,474.00
		Dental		\$ 62.38	\$ 51.26	82.17%	\$ 11.12		\$ 615.12	
8	New Ulm	Medical	3250/6500	\$ 647.48	\$ 647.48	100.00%	\$ -	\$ 1,371.12	\$ 9,140.88	\$ 9,357.60
		Dental		\$ 36.12	\$ 18.06	50.00%	\$ 18.06		\$ 216.72	
9	Faribault	Medical	2800	\$ 731.72	\$ 673.18	92.00%	\$ 58.54	\$ 660.00	\$ 8,738.16	\$ 8,738.16
		Dental		\$ 30.73	\$ -	0.00%	\$ 30.73		\$ -	
10	North Mankato	Medical	3500/7000	\$ 722.88	\$ 578.30	80.00%	\$ 144.58	\$ 1,750.00	\$ 8,689.60	\$ 8,689.60
		Dental		\$ 31.01	\$ -	0.00%	\$ 31.01		\$ -	
11	Hutchinson	Medical	2000	\$ 723.47	\$ 578.78	80.00%	\$ 144.69	\$ 1,000.00	\$ 7,945.36	\$ 8,560.48
		Dental		\$ 62.38	\$ 51.26	82.17%	\$ 11.12		\$ 615.12	
12	MARSHALL	Medical	2000	\$ 632.33	\$ 543.80	86.00%	\$ 88.53	\$ 1,500.00	\$ 8,025.60	\$ 8,486.04
		Dental		\$ 47.96	\$ 38.37	80.00%	\$ 9.59		\$ 460.44	
13	Owatonna	Medical	3375/6750	\$ 692.16	\$ 526.00	75.99%	\$ 166.16	\$ 1,225.00	\$ 7,537.00	\$ 7,537.00
		Dental		\$ 35.29		0.00%	\$ 35.29		\$ -	

**2022 Comparable Cities Survey--Health and Dental
Combined Employer Contribution
FAMILY PLANS**

TOTAL EMPLOYER CONTRIBUTION Rank High to Low			Deductible	Monthly Premium	Monthly Employer Contribution	%	Monthly Employee Contribution	Annual VEBA/HSA Employer Contribution	Total Annual Employer Contribution	TOTAL COMBINED EMPLOYER CONTRIBUTION
FAMILY									FAMILY	FAMILY
1	St Peter	Medical	1850	\$ 2,845.88	\$ 2,568.88	90.27%	\$ 277.00	\$ 2,250.00	\$ 33,076.56	\$ 34,181.76
		Dental		\$ 92.10	\$ 92.10	100.00%	\$ -	\$ 1,105.20	\$ 1,105.20	
2	Albert Lea	Medical	3250/6500	\$ 2,524.02	\$ 2,070.02	82.01%	\$ 454.00	\$ 1,900.00	\$ 26,740.24	\$ 26,740.24
		Dental		\$ 101.75	\$ -	0.00%	\$ 101.75	\$ -	\$ -	
3	Waseca	Medical	6400/8000	\$ 2,076.98	\$ 1,661.58	80.00%	\$ 415.40	\$ 6,158.00	\$ 26,096.96	\$ 26,096.96
		Dental		\$ 116.28	\$ -	0.00%	\$ 116.28	\$ -	\$ -	
4	Willmar	Medical	4000/6000	\$ 1,533.49	\$ 1,526.26	99.53%	\$ 7.23	\$ 6,000.00	\$ 24,315.12	\$ 24,315.12
		Dental		\$ 102.66	\$ -	0.00%	\$ 102.66	\$ -	\$ -	
5	North Mankato	Medical	3500/7000	\$ 2,105.82	\$ 1,684.66	80.00%	\$ 421.16	\$ 3,500.00	\$ 23,715.92	\$ 23,715.92
		Dental		\$ 102.61	\$ -	0.00%	\$ 102.61	\$ -	\$ -	
6	Faribault	Medical	2800	\$ 2,341.59	\$ 1,920.11	82.00%	\$ 421.48	\$ 660.00	\$ 23,701.32	\$ 23,701.32
		Dental		\$ 125.56	\$ -	0.00%	\$ 125.56	\$ -	\$ -	
7	Fairmont	Medical	5000/10000	\$ 1,929.14	\$ 1,743.38	90.37%	\$ 185.76	\$ 2,000.00	\$ 22,920.56	\$ 23,554.64
		Dental		\$ 75.49	\$ 52.84	70.00%	\$ 22.65	\$ 634.08	\$ 634.08	
8	New Ulm	Medical	3250/6500	\$ 1,977.52	\$ 1,582.02	80.00%	\$ 395.50	\$ 3,062.76	\$ 22,047.00	\$ 22,830.60
		Dental		\$ 130.60	\$ 65.30	50.00%	\$ 65.30	\$ 783.60	\$ 783.60	
9	Hutchinson	Medical	4000	\$ 1,808.26	\$ 1,446.61	80.00%	\$ 361.65	\$ 2,000.00	\$ 19,359.32	\$ 20,553.68
		Dental		\$ 122.71	\$ 99.53	81.11%	\$ 23.18	\$ 1,194.36	\$ 1,194.36	
10	MARSHALL	Medical	4000	\$ 1,673.51	\$ 1,405.75	84.00%	\$ 267.76	\$ 2,000.00	\$ 18,869.00	\$ 20,148.44
		Dental		\$ 133.28	\$ 106.62	80.00%	\$ 26.66	\$ 1,279.44	\$ 1,279.44	
11	Owatonna	Medical	3375/6750	\$ 1,914.94	\$ 1,467.00	76.61%	\$ 447.94	\$ 2,500.00	\$ 20,104.00	\$ 20,104.00
		Dental		\$ 101.88	\$ -	0.00%	\$ 101.88	\$ -	\$ -	
12	Northfield	Medical	3000/6000	\$ 1,830.68	\$ 1,340.34	73.22%	\$ 490.34	\$ 3,500.00	\$ 19,584.08	\$ 19,778.48
		Dental		\$ 121.62	\$ 16.20	13.32%	\$ 105.42	\$ 194.40	\$ 194.40	
13	Worthington	Medical	2000/4000	\$ 1,892.07	\$ 1,513.65	80.00%	\$ 378.42	\$ 1,500.00	\$ 19,663.80	\$ 19,663.80
		Dental						\$ -	\$ -	

2023 Health Insurance Cost-Share Proposals

Recommendation--Option A					8.8% increase to Both ER and EE				Maintain 80/20% cost share				
Past 2021 PEIP					Current 2022 BCBS				2023 BCBS		2023 Delta Dental		
Low Plan 1 - HSA/VEBA					\$2,000/\$4000 Deductible Non-Embedded HSA/VEBA				\$2,000/\$4000 Deductible Non-Embedded HSA/VEBA				
	Single	Family			Single	Family			Single	Family	Single	Family	
Monthly Premium	\$718.32	\$1,901.10			\$632.33	\$1,673.51			\$687.98	\$1,820.78	\$47.96	\$133.28	
Employer Contribution	\$624.84	87% \$1,618.79	85%		\$543.80	86% \$1,405.75	84%		\$591.66	86% \$1,529.46	84%	\$38.37	\$106.62
Employee Contribution	\$93.48	13% \$282.31	15%		\$88.53	14% \$267.76	16%		\$96.32	14% \$291.32	16%	\$9.59	\$26.66
ER Annual Premium	\$7,498.08	\$19,425.48			\$6,525.60	\$16,869.00			\$7,099.92	\$18,353.52	\$460.44	\$1,279.44	
EE Annual Premium	\$1,121.76	\$3,387.72			\$1,062.36	\$3,213.12			\$1,155.84	\$3,495.84	\$115.08	\$319.92	
ER HSA/VEBA contribution	\$1,500.00	\$2,000.00			\$1,500.00	\$2,000.00			\$1,500.00	\$2,000.00			
Total Annual ER contribution	\$8,998.08	\$21,425.48			\$8,025.60	\$18,869.00			\$8,599.92	\$20,353.52	\$8,748.36	\$84,443.04	
Continued annual increase (savings) to the City over 2021:					\$ (20,422.08)	\$ (158,501.76)			\$ (8,361.36)	\$ (66,461.52)			
# of contracts (as of 09/30/22):					21	62			21	62	19	66	
Estimated 2023 increase based on current contracts:									\$12,060.72	\$ 92,040.24	\$ 0.00	\$ 0.00	
									Total \$104,100.96		Total \$0.00		

Alternative--Option B					8.8% increase to Both ER and EE				75/25% cost share				
Past 2021 PEIP					Current 2022 BCBS				2023 BCBS		2023 Delta Dental		
Low Plan 1 - HSA/VEBA					\$2,000/\$4000 Deductible Non-Embedded HSA/VEBA				\$2,000/\$4000 Deductible Non-Embedded HSA/VEBA				
	Single	Family			Single	Family			Single	Family	Single	Family	
Monthly Premium	\$718.32	\$1,901.10			\$632.33	\$1,673.51			\$687.98	\$1,820.78	\$47.96	\$133.28	
Employer Contribution	\$624.84	87% \$1,618.79	85%		\$543.80	86% \$1,405.75	84%		\$591.66	86% \$1,529.46	84%	\$35.97	\$99.96
Employee Contribution	\$93.48	13% \$282.31	15%		\$88.53	14% \$267.76	16%		\$96.32	14% \$291.32	16%	\$11.99	\$33.32
ER Annual Premium	\$7,498.08	\$19,425.48			\$6,525.60	\$16,869.00			\$7,099.92	\$18,353.52	\$431.64	\$1,199.52	
EE Annual Premium	\$1,121.76	\$3,387.72			\$1,062.36	\$3,213.12			\$1,155.84	\$3,495.84	\$143.88	\$399.84	
ER HSA/VEBA contribution	\$1,500.00	\$2,000.00			\$1,500.00	\$2,000.00			\$1,500.00	\$2,000.00			
Total Annual ER contribution	\$8,998.08	\$21,425.48			\$8,025.60	\$18,869.00			\$8,599.92	\$20,353.52	\$8,201.16	\$79,168.32	
Continued annual increase (savings) to the City over 2021:					\$ (20,422.08)	\$ (158,501.76)			\$ (8,361.36)	\$ (66,461.52)			
# of contracts (as of 09/30/22):					21	62			21	62	19	66	
Estimated 2023 increase (savings) based on current contracts:									\$12,060.72	\$92,040.24	\$ (547.20)	\$ (5,274.72)	
									Total \$104,100.96		Total: \$ (5,821.92)		

Presenter:	Jason Anderson
Meeting Date:	Tuesday, October 25, 2022
Category:	NEW BUSINESS
Type:	ACTION
Subject:	Project ST-015 / SP 4204-40): 2025 MnDOT College Drive Improvement Project - Consider Resolution for Municipal Consent and Layout Approval.
Background Information:	<p>MnDOT is proceeding with plans to complete State Project 4204-40, Reconstruction of Hwy 19 from 4th Street to Bruce Street. In accordance with Minnesota Statute 161.164, MnDOT is submitting for City approval the project’s Final Layout Flap, identified as Layout Flap No. 1A, S.P. 4204-40. Layout Flap No. 1A is the result of the City’s request to include Bruce Street in the project plans. By including Bruce Street, the City is able to make necessary improvements to our water, sewer and storm sewer systems.</p> <p>The City’s approval (municipal consent) is required for this project because it alters access (many accesses will be closed and / or altered to right in right out), requires acquisition of permanent rights of way (permanent right of way will be obtained to bring city alleys to city access standards). Municipal consent of MnDOT projects is described in Minnesota Statutes 161.162 through 161.167 (attached).</p> <p>Approval or disapproval of the final layout flap is by resolution of the City Council. However, if the City neither approves nor disapproves the final layout flap within 60 days from the date the commissioner submits them, the layout is deemed approved (per MN Statute 161.164).</p> <p>Included with this memorandum is a “Municipal Consent Packet” as provided by Jesse Vlaminck, MnDOT Project Manager. The packet includes a memorandum, applicable State Statutes, project schedule, project cost estimate, and resolutions for the City to utilize for offering municipal consent. Also included with MnDOT’s submittal is the final layout to be used for the project. The final layout provides the basis for the project as it highlights the general concept for the project by identifying all key features and access points for the highway.</p> <p>During the previous municipal consent layout approval proceedings, State Statutes requirements were fulfilled as follows:</p> <ul style="list-style-type: none"> - City to schedule a public hearing within 15 days of receiving the final layout (by 7/28/2021) and the public hearing was scheduled at the 07/13/2021 City Council meeting to be held 08/24/2021. - Conduct a public hearing within 60 days of receiving the final layout (by 9/11/2021) and the public hearing was held at the 08/24/2021 City Council meeting. - Approve or disapprove the layout by resolution within 90 days of the public hearing (by 12/10/2021) and the resolution was approved on 08/24/2021. <p>State Statutes will require the following:</p> <ul style="list-style-type: none"> - Approve or disapprove of the layout flap submittal by resolution within 60 days of the flap submittal (by 12/26/2022).

	MnDOT Project Manager, Jesse Vlaminc is present at this meeting to help present this topic and answer City Council questions. Jesse will help explain the additional municipal consent process and guide Council expectations moving forward.
Fiscal Impact:	No fiscal impact at this time. A future estimated total city cost of \$5,179,680 at time of College Drive reconstruction project. All improvements may be assessed according to the current Special Assessment Policy, including but not limited to participation from Marshall Municipal Utilities, Wastewater Department, Surface Water Management Utility Fund and Ad Valorem. Final approval of the project must include determination of funding sources.
Alternative/ Variations:	No alternative actions recommended.
Recommendations:	that the Council adopt RESOLUTION NUMBER 22-___, which is the "Resolution for Municipal Consent and Layout Approval."

RESOLUTION NO. 22-_____
RESOLUTION FOR MUNICIPAL CONSENT AND LAYOUT APPROVAL

WHEREAS, the Commissioner of Transportation has prepared a final layout flap for State Project 4204- 40: College Drive Improvement Project on Trunk Highway 19, from 4th Street to Bruce Street within the City of Marshall for Reconstruction improvements; and seeks the approval thereof, as described in Minnesota Statutes 161.162 to 161.167; and

WHEREAS, said final layout flap is on file in the District 8 Minnesota Department of Transportation office, Willmar, Minnesota, being marked as Layout Flap No. 1A, S.P. 4204-40, from R.P. 34+00.012 to 35+00.514.

NOW, THEREFORE, BE IT RESOLVED that said final layout for the improvement of said Trunk Highway within the corporate limits be and is hereby approved.

Passed and adopted by the City Council this 25th day of October, 2022.

ATTEST:

City Clerk

Mayor

Upon the call of the roll the following Council Members voted in favor of the Resolution:

The following Council Members voted against its adoption:

At a Meeting of the City Council of the City of Marshall, held on the 25th day of October, 2022, the following Resolution was offered by _____ and seconded by _____ that the Council adopt RESOLUTION NUMBER 22-____, which is the "Resolution for Municipal Consent and Layout Approval."

State of Minnesota, County of Lyon, City of Marshall

I do hereby certify that the foregoing Resolution is a true and correct copy of a resolution presented to and adopted by the Council of the City of Marshall, Minnesota at a duly authorized meeting thereof held on the 25th day of October, 2022, as shown by the minutes of said meeting in my possession.

(SEAL)

Steven Anderson
City Clerk

LAYOUT HISTORY

LAYOUT FLAP HISTORY

JUNE 2022: BASED ON COORDINATION WITH THE CITY OF MARSHALL IT WAS DETERMINED THAT THE INTERSECTION OF BRUCE STREET AND TH 19 WOULD BE INCLUDED IN THE SP 4204-40 HWY 19 RECONSTRUCTION PROJECT BASED ON THE CITY UTILITIES THAT ARE PLANNING TO BE REPLACED THROUGHOUT THE INTERSECTION.

AUGUST 2022: BASED ON COMMENTS PROVIDED BY GDSU THE 1:55 TAPER ON TH 19 WEST OF BRUCE STREET WAS EXTENDED TO EXISTING ALIGNMENT ALLOWING THE STRIP BETWEEN WB LANES TO MOVE OVER ONE FOOT WHICH ALIGNS THE LANES THROUGH THE INTERSECTION.

LAYOUT NOTES

1. ALL PEDESTRIAN FACILITIES ARE TO MEET ADA/PROWAG REQUIREMENTS.
2. NO DESIGN EXCEPTIONS.
3. TH 19 IS NOT A HOUSE MOVING CORRIDOR.
4. TH 19 IS NOT A SUPERLOAD OSOW CORRIDOR.

LAYOUT FLAP No. 1A COPY No. _____
 T.H. 19 VICINITY OF MARSHALL, MN
 FROM 4TH STREET S. TO BRUCE STREET N.
 Prepared JUNE 20 22 Scdlter Hor. 1 Inch = 50 ft.

By **LSRF**
 The alignment and Staff Approval
 grades shown on Date 08-12-2022
 this map are tentative and subject to change without notice.
 The traffic volumes shown are estimated for year 2045.
 Evaluation Report Control
 Prepared MARCH 20 02

S.P. 4204-40 T.H. 19=014 A.J. T8A933 PPMS Activity 1140
 S.A.P. 139-111-007PR
 S.A.P. 139-112-006PR
 S.A.P. 139-115-004PR
 S.A.P. 139-122-007PR
 S.A.P. 139-124-005PR

Copy To: _____ For: _____
 DESIGN FILE: p:\a\1\p\2\hwy\comser\Fpw\Documents\Projects\4204\14743\Tech\Drawn\Layout\Layout\vd020440_lob_Flapp.dgn
 DATE: 8/29/2022 - DATE PLOTTED

LAYOUT FLAP APPROVAL
 Programmed Letting Date 1/24/2025
 Prepared By **LSRF**
 Isac Kinuthia Digitally signed by Isac Kinuthia Date: 2022.08.30 11:40:19 -0500
 District B Preliminary Design Engineer
 Cody Brand Digitally signed by Cody Brand Date: 2022.08.30 12:25:26 -0500
 District B Traffic Engineer
 Douglas Carter Digitally signed by Douglas Carter Date: 2022.08.31 10:52:42 -0500
 State Geometric Engineer
 Jon Huseby Digitally signed by Jon Huseby Date: 2022.08.07 09:17:57 -0500
 District B Traffic Engineer
 Tom Styrbicki Digitally signed by Tom Styrbicki Date: 2022.08.12 14:30:06 -0500
 State Design Engineer

I HEREBY CERTIFY THAT THIS LAYOUT WAS PREPARED BY ME OR UNDER MY DIRECT SUPERVISION AND THAT I AM A LICENSED PROFESSIONAL ENGINEER UNDER THE LAWS OF THE STATE OF MINNESOTA.
 DATE: 08/24/2022. LIC. NO.: 53858 ENGR. I
 KYLE FABRISON

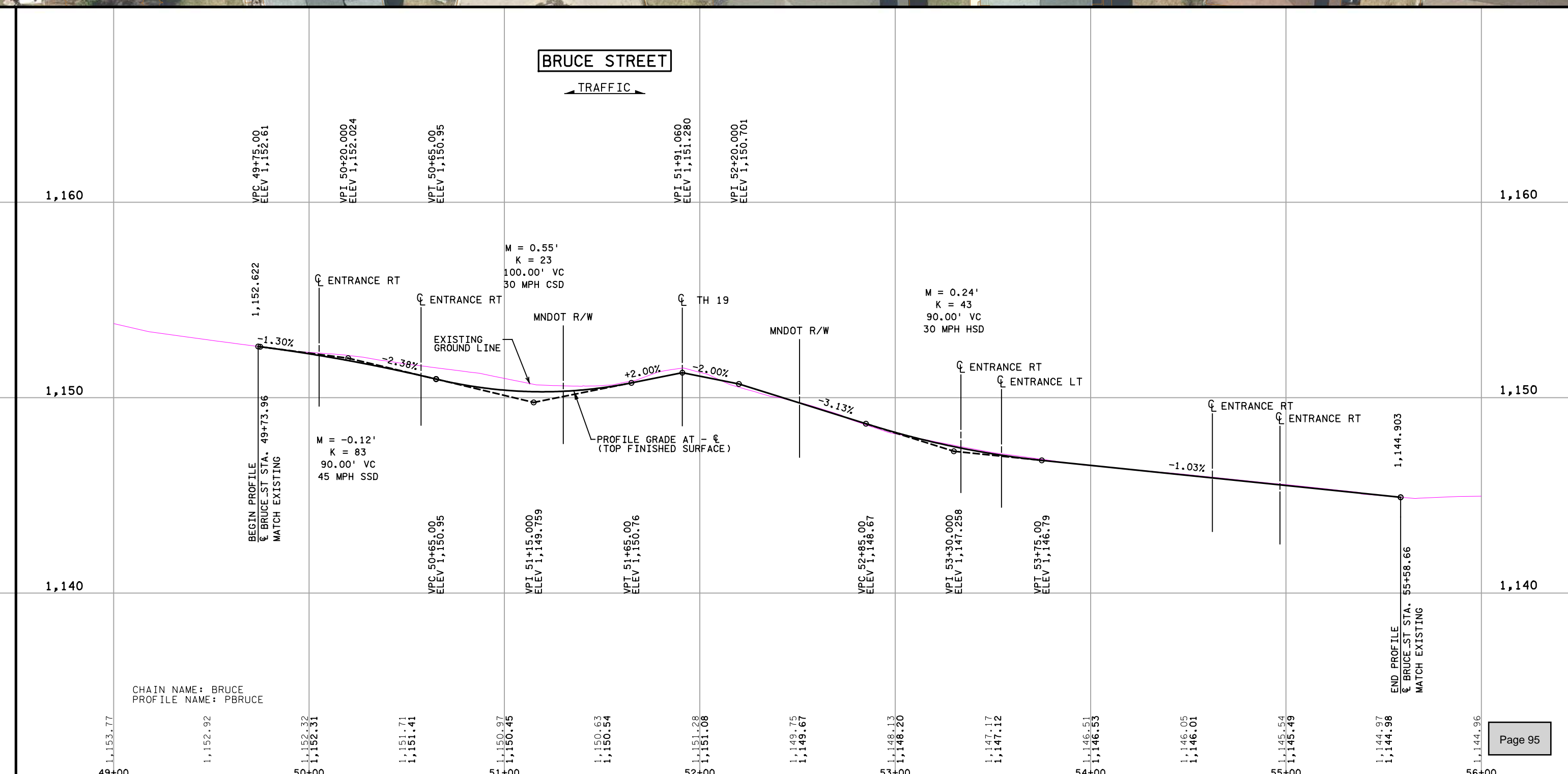
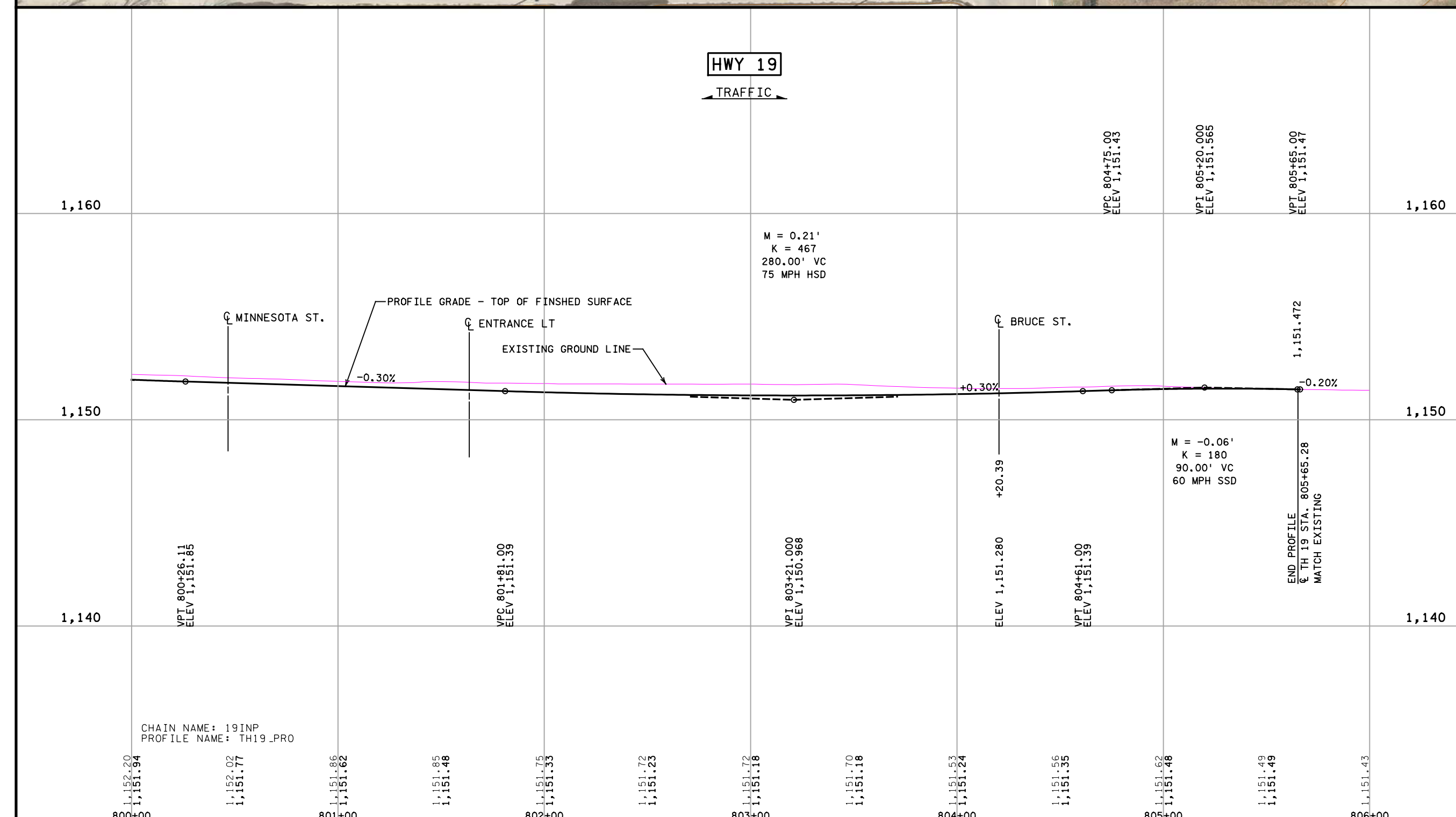
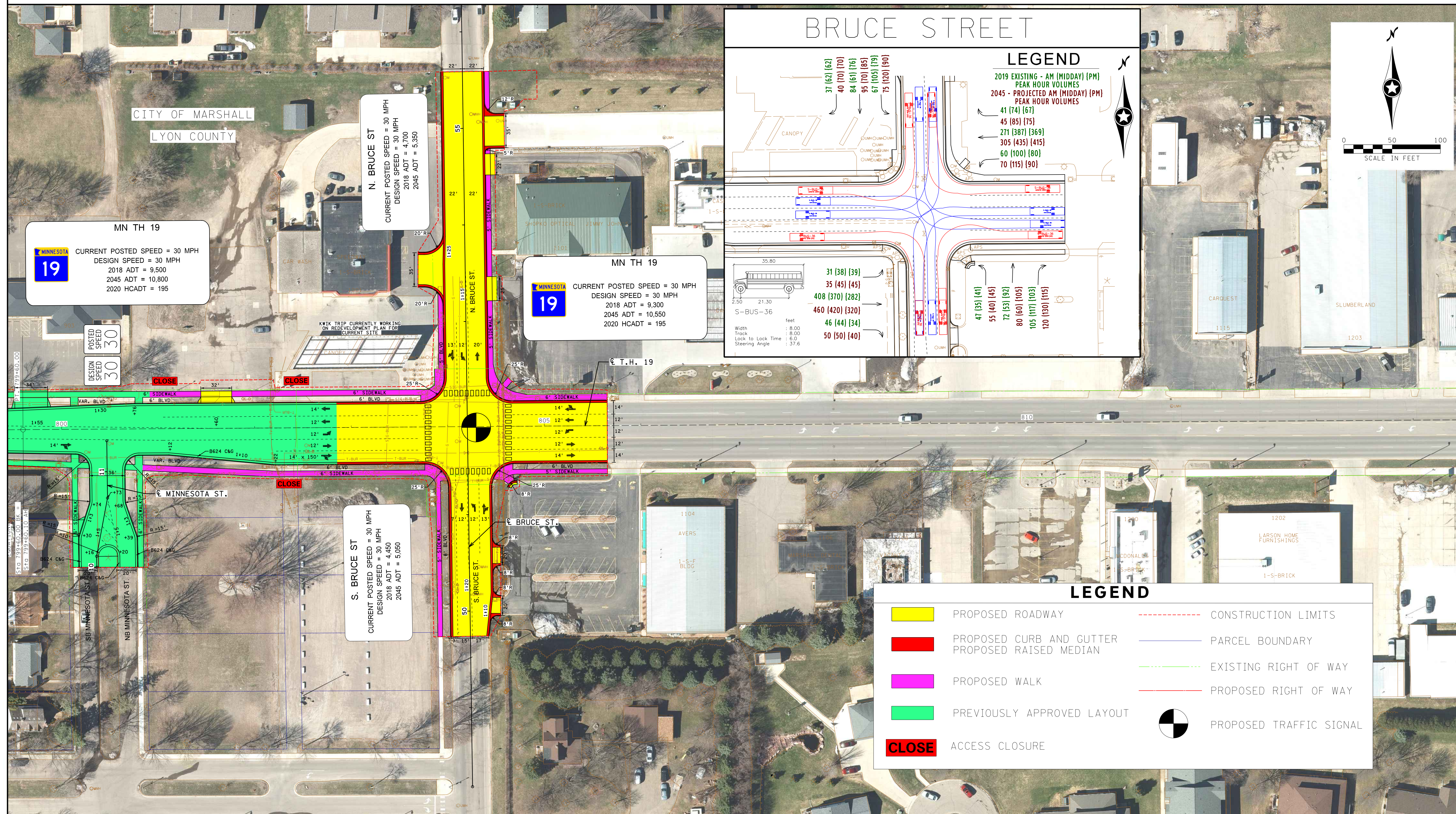
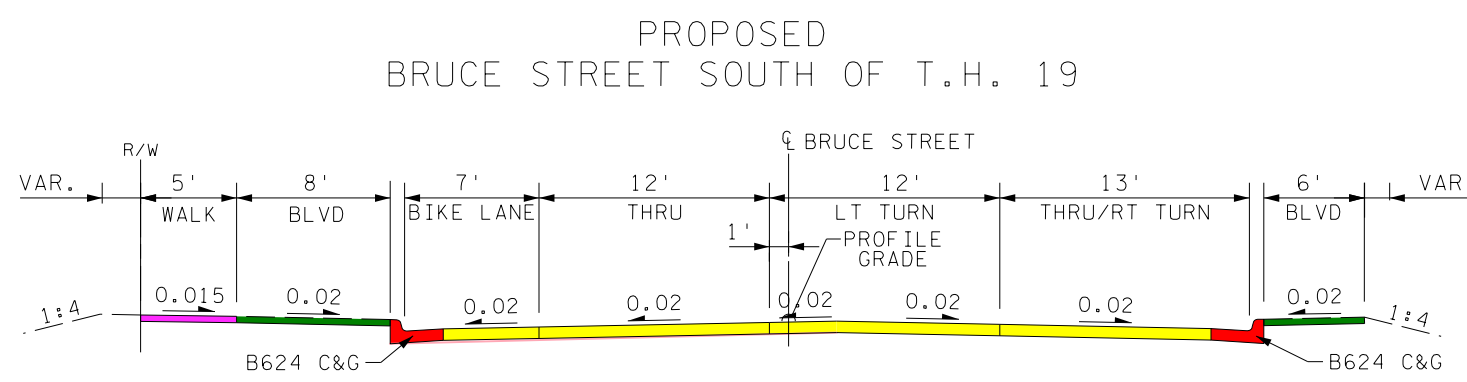
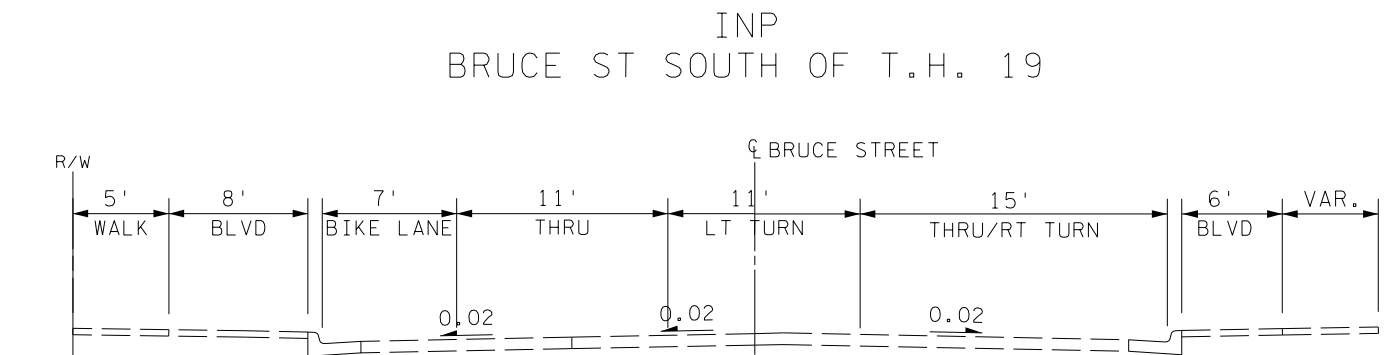
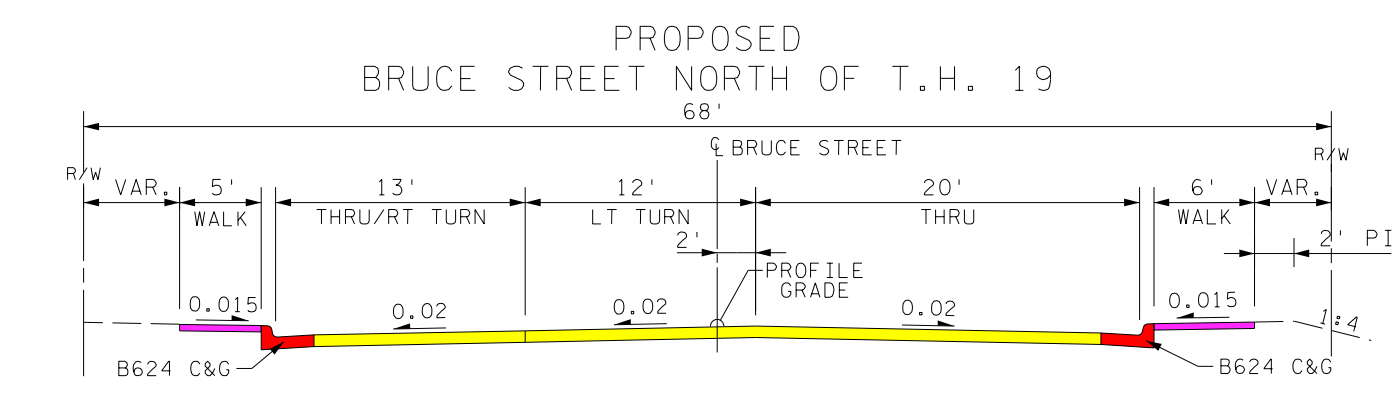
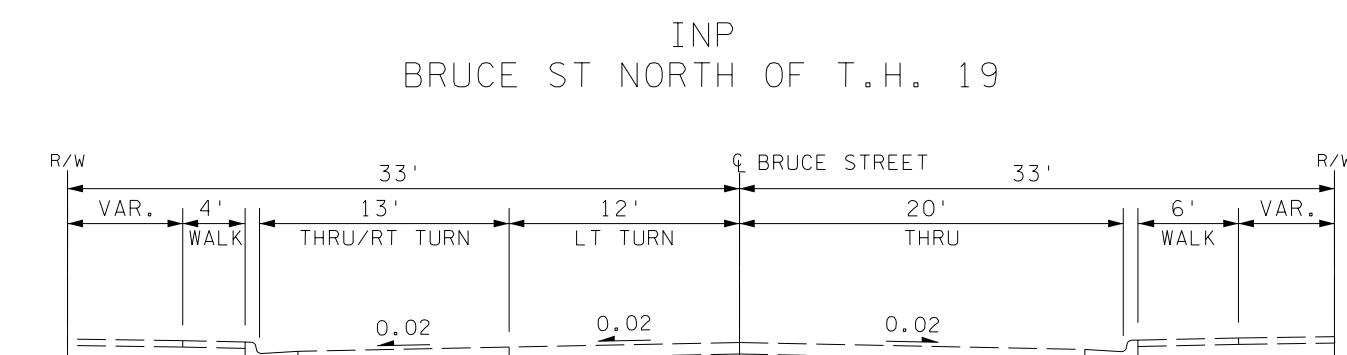
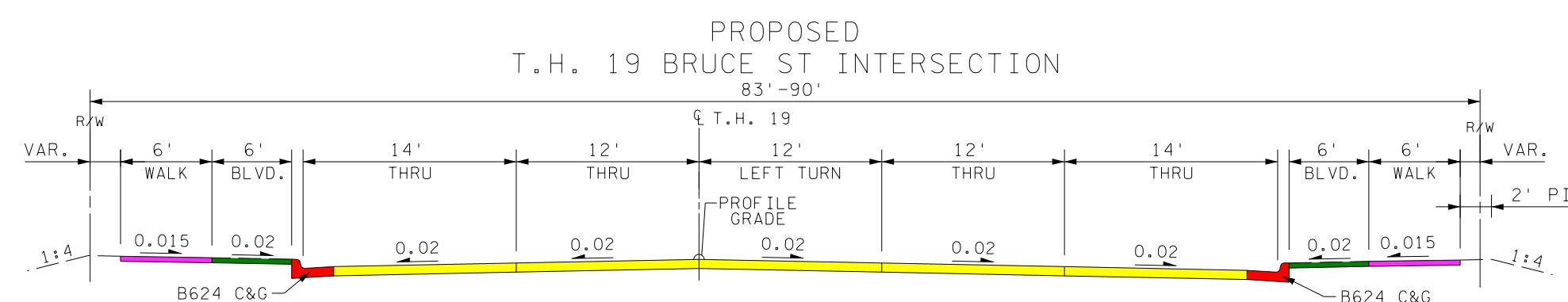
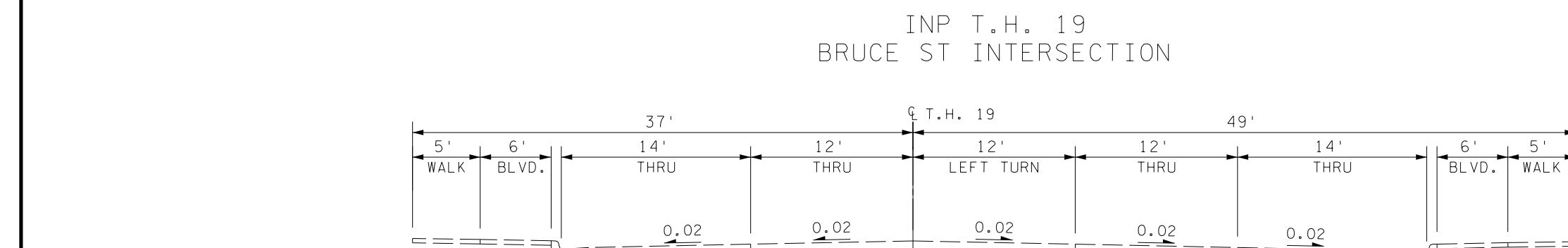

Municipal Consent

SP 4204-40

City of Marshall

October 25, 2022

Municipal consent submittal letter

SP 4204-40 Layout Flap 1A - Separate file (Signed copy to be hand delivered)

State Statues 161.162 through 161.167

Project schedule

Current Cost Estimate

Sample Resolution for Municipal Consent

Sample Resolution to Waive Municipal Consent

October 5, 2022

Robert J. Byrnes
Mayor
City of Marshall
344 West Main Street
Marshall, MN 5658

RE: Request for City Approval (Municipal Consent) of the Final Layout Flap for SP 4204-40

Dear Mayor Byrnes

MnDOT is proceeding with plans to complete State Project 4204-40, Reconstruction of Hwy 19 from 4th Street to Bruce Street. In accordance with Minnesota Statute 161.164, I am submitting for City approval the project's Final Layout Flap, identified as Layout Flap No. 1A, S.P. 4204-40.

The City's approval (municipal consent) is required for this project because it alters access (Many access will be closed and /or altered to right in right out), requires acquisition of permanent rights of way (permanent right of way will be obtained to bring city alleys to city access standards). Municipal consent of MnDOT projects is described in Minnesota Statutes 161.162 through 161.167 (attached).

Approval or disapproval of the final layout flap is by resolution of the City Council. (A sample resolution is attached). However, if the city neither approves nor disapproves the final layout flap within 60 days from the date the commissioner submits them, the layout is deemed approved (per MN Statute 161.164).

The deadlines (per MN Statute 161.164) for the City's responsibilities regarding municipal consent of the attached layout flap are as follows, based on a submittal date of the final layout to the City of [10/25/2022]:

- Within 60 days of the layout flap submittal, approve or disapprove the layout by resolution (by 12/26/2022).

Project Purpose

This project has a deteriorated pavement, indicated by a sub-standard Ride Quality Index (RQI) rating. The RQI rating is projected to continue to decline. This project also has pedestrian access facilities, ramps and sidewalks that do not meet the Americans with Disabilities Act (ADA) standards. This project also has aging underground city utilities; sewer and water mains that are in poor condition.

The purpose of this project is to:

- A) Improve the RQI on this project which will help the entire Highway System achieve the Pavement Performance Targets, and to improve pavement structural integrity and reduce maintenance costs.
- B) Upgrade the pedestrian ramps/sidewalk to meet ADA standards
- C) Facilitate replacement of the deteriorating underground utilities.

Project Description

SP 4204-40 will be a full reconstruction of Trunk Highway (TH) 19 from 4th Street to approximately 134' west of Bruce Street in Marshall, MN. The project will include but not limited to Concrete Paving, a Roundabout at the intersection of Hwy 19, Country Club Drive, and South 2nd Street, new Signals at Saratoga Street and Main Street (TH 59), Rectangular Rapid Flashing Beacons (RRFB), Bridge approach panel work at Bridge No. 5083, Lighting, Storm Sewer, City utilities (Sanitary and Water), and some additional sidewalk and pedestrian curb ramps from Marlene Street to 4th Street and at Bruce Street.

Planned Project Schedule

SP 4204-40 is planned to be let on November 22, 2024, Construction is to begin the spring of 2025 and is anticipated to take up to two construction seasons to complete all work, there will be detours and staged construction.

City's Estimated Project Costs

Some project costs are the City's responsibility, as detailed in MnDOT's cost participation policy. (See the policy and the *Cost Participation and Maintenance with Local Units of Government Manual* at MnDOT's this website: <http://www.dot.state.mn.us/policy/financial/fm011.html>).

Attached is MnDOT's current estimate of the City's costs for S.P. 4204-40. It also shows MnDOT's estimated costs.

As shown on the attached, the City of Marshall's total cost participation for SP 4204-40 is estimated to be \$5,179,680.

The alleys between West Lyon and West Marshall streets will require additional Right of Way (R/W) to be built to city standards. It is the intent for MnDOT to obtain the R/W to construct the alleys to standard and then turn back to the city.

City's Maintenance Responsibilities

The City of Marshall will also be responsible for the following:

- Approach legs to the intersections to the outside edge of the shoulder line or outer radius of roundabouts.
- Removal of snow from parking lanes.

- Responsible for maintenance of Parking- related markings installed on MnDOT roadways.
- Routine maintenance of all sidewalks and shared use paths, including but not limited to patching, snow and ice control/removal, sweeping, debris removal, vegetation control, signs, and pavement markings.

MnDOT will be responsible for the following:

- Maintenance activities associated with all trunk highway roadway and shoulder items.
- Non-routine storm sewer system maintenance is defined as removal of sediment from the pipes, replacement, reconstruction, rehabilitation, or improvement of portions of storm water drainage infrastructure such as castings, manhole or catch basin structures, and pipe segments or aprons, including rip-rap.

Please feel free to contact me if you have any questions about this submittal.

Sincerely,

Jesse Vlaminc /s/

Jesse Vlaminc
Project Manager
MnDOT District 8
2505 Transportation Road
Willmar, MN 56201
320-212-0206
jesse.vlaminck@state.mn.us

Attachments:

Final Layout Flap for SP 4204-40, dated 9/12/2022
MN Statutes 161.162 – 161.167
Estimated Project Costs
Project Schedule
Sample City Resolution
Sample City Waiver Resolution

cc:

Sharon Hanson – Marshall City Administrator
Jason Anderson – Marshall City Engineer

161.162 DEFINITIONS.

Subdivision 1. **Applicability.** The terms in sections 161.162 to 161.167 have the meanings given them in this section and section 160.02.

Subd. 2. **Final layout.** (a) "Final layout" means geometric layouts and supplemental drawings that show the location, character, dimensions, access, and explanatory information about the highway construction or improvement work being proposed. "Final layout" includes, where applicable, traffic lanes, shoulders, trails, intersections, signals, bridges, approximate right-of-way limits, existing ground line and proposed grade line of the highway, turn lanes, access points and closures, sidewalks, proposed design speed, noise walls, transit considerations, auxiliary lanes, interchange locations, interchange types, sensitive areas, existing right-of-way, traffic volume and turning movements, location of storm water drainage, location of municipal utilities, project schedule and estimated cost, and the name of the project manager.

(b) "Final layout" does not include a cost participation agreement. For purposes of this subdivision "cost participation agreement" means a document signed by the commissioner and the governing body of a municipality that states the costs of a highway construction project that will be paid by the municipality.

Subd. 3. **Final construction plan.** "Final construction plan" means the set of technical drawings for the construction or improvement of a trunk highway provided to contractors for bids.

Subd. 4. **Governing body.** "Governing body" means the elected council of a municipality.

Subd. 5. **Municipality.** "Municipality" means a statutory or home rule charter city.

History: 2001 c 191 s 3; 2002 c 364 s 3

161.163 HIGHWAY PROJECT REVIEW.

Subdivision 1. **Projects requiring review.** Sections 161.162 to 161.167 apply only to projects that alter access, increase or reduce highway traffic capacity, or require acquisition of permanent rights-of-way.

Subd. 2. **Traffic safety measures.** Nothing contained in sections 161.162 to 161.167 limits the power of the commissioner to regulate traffic or install traffic-control devices or other safety measures on trunk highways located within municipalities regardless of their impact on access or traffic capacity or on the need for additional right-of-way.

Subd. 3. **Construction program.** Nothing contained in sections 161.162 to 161.167 limits the commissioner's discretion to determine priority and programming of trunk highway projects.

History: 2001 c 191 s 4

161.164 FINAL LAYOUT APPROVAL PROCESS.

Subdivision 1. **Submission of final layout.** Before proceeding with the construction, reconstruction, or improvement of any route on the trunk highway system lying within any municipality, the commissioner shall submit to its governing body a final layout and project report covering the purpose, route location, and proposed design of the highway. The final layout must be submitted as part of a report containing any supporting data that the commissioner deems helpful to the governing body in reviewing the final layout submitted. The supporting data must include a good-faith cost estimate of all the costs in which the governing body is expected to participate. The final layout must be submitted before final decisions are reached so that meaningful early input can be obtained from the municipality.

Subd. 2. **Governing body action.** (a) Within 15 days of receiving a final layout from the commissioner, the governing body shall schedule a public hearing on the final layout. The governing body shall, within 60 days of receiving a final layout from the commissioner, conduct a public hearing at which the Department of Transportation shall present the final layout for the project. The governing body shall give at least 30 days' notice of the public hearing.

(b) Within 90 days from the date of the public hearing, the governing body shall approve or disapprove the final layout in writing, as follows:

(1) If the governing body approves the final layout or does not disapprove the final layout in writing within 90 days, in which case the final layout is deemed to be approved, the commissioner may continue the project development.

(2) If the final construction plans contain changes in access, traffic capacity, or acquisition of permanent right-of-way from the final layout approved by the governing body, the commissioner shall resubmit the portion of the final construction plans where changes were made to the governing body. The governing body must approve or disapprove the changes, in writing, within 60 days from the date the commissioner submits them.

(3) If the governing body disapproves the final layout, the commissioner may make modifications requested by the municipality, decide not to proceed with the project, or refer the final layout to an appeal board. The appeal board shall consist of one member appointed by the commissioner, one member appointed by the governing body, and a third member agreed upon by both the commissioner and the governing body. If the commissioner and the governing body cannot agree upon the third member, the chief justice of the supreme court shall appoint a third member within 14 days of the request of the commissioner to appoint the third member.

Subd. 3. **Appeal board.** Within 30 days after referral of the final layout, the appeal board shall hold a hearing at which the commissioner and the governing body may present the case for or against approval of the final layout referred. Not later than 60 days after the hearing, the appeal board shall recommend approval, recommend approval with modifications, or recommend disapproval of the final layout, making additional recommendations consistent with state and federal requirements as it deems appropriate. It shall submit a written report containing its findings and recommendations to the commissioner and the governing body.

History: 2001 c 191 s 5

161.165 COMMISSIONER ACTION; INTERSTATE HIGHWAYS.

Subdivision 1. **Applicability.** This section applies to interstate highways.

Subd. 2. **Action on approved final layout.** (a) If the appeal board recommends approval of the final layout or does not submit its findings and recommendations within 60 days of the hearing, in which case the final layout is deemed approved, the commissioner may prepare substantially similar final construction plans and proceed with the project.

(b) If the final construction plans change access, traffic capacity, or acquisition of permanent right-of-way from the final layout approved by the appeal board, the commissioner shall submit the portion of the final construction plans that shows the changes, to the governing body for its approval or disapproval under section 161.164, subdivision 2.

Subd. 3. **Action on final layout approved with changes.** (a) If, within 60 days, the appeal board recommends approval of the final layout with modifications, the commissioner may:

(1) prepare final construction plans with the recommended modifications, notify the governing body, and proceed with the project;

(2) decide not to proceed with the project; or

(3) prepare final construction plans substantially similar to the final layout referred to the appeal board, and proceed with the project. The commissioner shall, before proceeding with the project, file a written report with the governing body and the appeal board stating fully the reasons for doing so.

(b) If the final construction plans contain changes in access or traffic capacity or require additional acquisition of permanent right-of-way from the final layout reviewed by the appeal board or the governing body, the commissioner shall resubmit the portion of the final construction plans that shows the changes, to the governing body for its approval or disapproval under section 161.164, subdivision 2.

Subd. 4. **Action on disapproved final layout.** (a) If, within 60 days, the appeal board recommends disapproval of the final layout, the commissioner may either:

(1) decide not to proceed with the project; or

(2) prepare final construction plans substantially similar to the final layout referred to the appeal board, notify the governing body and the appeal board, and proceed with the project. Before proceeding with the project, the commissioner shall file a written report with the governing body and the appeal board stating fully the reasons for doing so.

(b) If the final construction plans contain changes in access or traffic capacity or require additional acquisition of permanent right-of-way from the final layout reviewed by the appeal board or the governing body, the commissioner shall resubmit the portion of the final construction plans that shows the changes, to the governing body for its approval or disapproval under section 161.164, subdivision 2.

Subd. 5. **Final construction plans issued.** The commissioner shall send a complete set of final construction plans to the municipality at least 45 days before the bid opening for informational purposes.

History: 2001 c 191 s 6

161.166 COMMISSIONER ACTION; OTHER HIGHWAYS.

Subdivision 1. **Applicability.** This section applies to trunk highways that are not interstate highways.

Subd. 2. **Action on approved final layout.** If the appeal board recommends approval of the final layout or does not submit its findings or recommendations within 60 days of the hearing, in which case the final layout is deemed approved, the commissioner may prepare substantially similar final construction plans and proceed with the project. If the final construction plans change access or traffic capacity or require additional acquisition of right-of-way from the final layout approved by the appeal board, the commissioner shall submit the portion of the final construction plan that shows the changes, to the governing body for its approval or disapproval under section 161.164, subdivision 2.

Subd. 3. **Action on final layout approved with changes.** (a) If the appeal board approves the final layout with modifications, the commissioner may:

(1) prepare final construction plans including the modifications, notify the governing body, and proceed with the project;

(2) decide not to proceed with the project; or

(3) prepare a new final layout and resubmit it to the governing body for approval or disapproval under section 161.164, subdivision 2.

(b) If the final construction plans contain changes in access or traffic capacity or require additional acquisition of permanent right-of-way from the final layout reviewed by the appeal board or the governing body, the commissioner shall resubmit the portion of the final construction plans that shows the changes, to the governing body for its approval or disapproval under section 161.164, subdivision 2.

Subd. 4. **Action on disapproved final layout.** If the appeal board disapproves the final layout, the commissioner may:

(1) decide not to proceed with the project; or

(2) prepare a new final layout and submit it to the governing body for approval or disapproval under section 161.164, subdivision 2.

Subd. 5. **Final construction plans issued.** The commissioner shall send a complete set of final construction plans to the municipality at least 45 days before the bid opening for informational purposes.

History: 2001 c 191 s 7; 2020 c 83 art 1 s 51

161.167 REIMBURSEMENT OF EXPENSES.

Members of the appeal board shall submit to the commissioner an itemized list of the expenses incurred in disposing of matters presented to them. The appeal board members shall be reimbursed for all reasonable expenses incurred by them in the performance of their duties. The commissioner shall pay these costs out of the trunk highway fund.

History: 2001 c 191 s 8

Project Schedule – 4204-40

15% Detailed Design/ADA Detailed Design Submittal	November 2022
30% Detailed Design/ADA Detailed Design Submittal	March 2023
60% Detailed Design/ADA Detailed Design Submittal	August 2023
90% Detailed Design/ADA Detailed Design Submittal	January 2023
100% Detailed Design/ADA Detailed Design Submittal	July 2024
Project Letting	November 2024
Begin Construction	Spring 2025



TH 19 Marshall

Concept Cost Estimate (based upon 2020 bid price information)
 Prepared By: SRF Consulting Group, Inc., September, 29, 2022

ITEM DESCRIPTION	UNIT	UNIT PRICE	TH 19 - MnDOT		TH 19 - CITY		TOTAL		
			EST. QUANTITY	EST. AMOUNT	EST. QUANTITY	EST. AMOUNT	EST. QUANTITY	EST. AMOUNT	
PAVING AND GRADING COSTS									
1 Local & Frontage Road Pavement (Bituminous)	(1)	sq. yd.	\$35.00	5,240	\$183,400	2,090	\$73,150	7,330	\$256,550
2 Concrete Walk / Trail / Median	(2)	sq. yd.	\$75.00	15,050	\$1,128,750	870	\$65,250	15,920	\$1,194,000
3 Truck Apron, Driveway & Alleyway	(1)	sq. yd.	\$81.00	4,450	\$360,450	760	\$61,560	5,210	\$422,010
4 Mainline Pavement (TH 19-Concrete)	(1)(6)	sq. yd.	\$81.00	32,440	\$2,627,640	1,350	\$109,350	33,790	\$2,736,990
5 Mainline Shoulder Pavement (parking)	(1)(3)	sq. yd.	\$81.00	780	\$63,180	90	\$7,290	870	\$70,470
6 2106 Excavation - common & subgrade		cu. yd.	\$10.00	60,700	\$607,000	4,600	\$46,000	65,300	\$653,000
7 2106 Common Embankment (CV)		cu. yd.	\$4.00	75,000	\$300,000	2,900	\$11,600	77,900	\$311,600
8 2106 Granular Subgrade (CV)		cu. yd.	\$25.00	47,800	\$1,195,000	3,500	\$87,500	51,300	\$1,282,500
9 Contaminated Materials Hauling	(5)	cu. yd.	\$5.00	200	\$1,000	800	\$4,000	1,000	\$5,000
10 Bridge No 5083. - Approach Panels		sq. yd.	\$25.00	155	\$3,875			155	\$3,875
11 ADA Pedestrian Curb Ramp		each	\$1800.00	86	\$154,800	8	\$14,400	94	\$169,200
12 Concrete Curb and Gutter		lin. ft.	\$35.00	18,370	\$642,950	2,080	\$72,800	20,450	\$715,750
SUBTOTAL PAVING AND GRADING COSTS:					\$7,312,920		\$592,900		\$7,905,820
DRAINAGE, UTILITIES AND EROSION CONTROL									
1 Removals - Pavement		sq. yd.	\$6.00	48,290	\$289,740	3,930	\$23,580	52,220	\$313,320
2 Local Utilities - Sanitary Sewers	(9)	l.s.	\$499,500			1	\$499,500	1	\$499,500
3 Local Utilities - Watermains	(9)	l.s.	\$483,900			1	\$483,900	1	\$483,900
4 Local Utilities - Storm Sewers	(9)	l.s.	\$486,000			1	\$486,000	1	\$486,000
5 Drainage - urban		25%			\$1,829,000				\$1,829,000
6 Traffic Control		3%			\$220,000		\$18,000		\$238,000
7 Dewatering		10%		0.3	\$237,300	0.7	\$553,700	1	\$791,000
8 Turf Establishment & Erosion Control		3%			\$220,000		\$18,000		\$238,000
9 Landscaping									
SUBTOTAL DRAINAGE, UTILITIES AND EROSION CONTROL					\$2,796,040		\$2,082,680		\$4,878,720
SIGNAL AND LIGHTING COSTS									
1 Signals (permanent)	(4)	each	\$250,000	2	\$500,000	1	\$250,000	3	\$750,000
2 Roadway Lighting (MnDOT)	(7)	each	\$7,000	8	\$56,000	4	\$28,000	12	\$84,000
3 Roadway Lighting (City)	(8)	each	\$3,100			17	\$52,700	17	\$52,700
4 Decorative Lighting (Single Assembly)	(8)	each	\$4,000			17	\$68,000	17	\$68,000
5 Decorative Lighting (Double Assembly)	(8)	each	\$6,400			22	\$140,800	22	\$140,800
6 Decorative Lighting (Intersection Lighting)	(8)	each	\$1,600			8	\$12,800	8	\$12,800
7 Ped Flasher System (RRFB)		each	\$78,000	1	\$78,000			1	\$78,000
8 Landscaping		l.s.	\$20,800			1	\$20,800	1	\$20,800
SUBTOTAL SIGNAL AND LIGHTING COSTS:					\$634,000		\$573,100		\$1,207,100
SIGNING & STRIPING COSTS									
1 Mainline Signing (C&D)		mile	\$35,000	1.7	\$59,500	0.3	\$10,500	2	\$70,000
2 Mainline Striping		mile	\$5,000	1.7	\$8,500	0.3	\$1,500	2	\$10,000
SUBTOTAL SIGNING & STRIPING COSTS:					\$68,000		\$12,000		\$80,000
SUBTOTAL CONSTRUCTION COSTS:					\$10,810,960		\$3,260,680		\$14,071,640
MISCELLANEOUS COSTS									
1 Mobilization		5%			\$541,000		\$164,000		\$705,000
2 Non Quantified Minor Items									
3 Temporary Pavement & Drainage		5%			\$541,000		\$164,000		\$705,000
SUBTOTAL MISCELLANEOUS COSTS:					\$1,082,000		\$328,000		\$1,410,000
ESTIMATED TOTAL CONSTRUCTION COSTS without Contingency:					\$11,892,960		\$3,588,680		\$15,481,640
1 Contingency or "risk"		10%			\$1,190,000		\$359,000		\$1,549,000
ESTIMATED TOTAL CONSTRUCTION COSTS PLUS CONTINGENCY:					\$13,082,960		\$3,947,680		\$17,030,640
INFLATION COST (CURRENT YR. TO YR. OF OPENING)		Factor	14%		\$1,900,000		\$600,000		\$2,500,000
					\$14,982,960		\$4,547,680		\$19,530,640
OTHER PROJECT COSTS:									
DESIGN ENG. & CONSTRUCTION ADMIN.		Lump Sum	16%		\$2,094,000		\$632,000		\$2,726,000
TOTAL PROJECT COST (OPENING YEAR DOLLARS)					\$17,076,960		\$5,179,680		\$22,256,640

NOTE (1) Assumed pavement and aggregate depths:
 TH 19 Concrete Pavement - 8" Concrete / 6" Class 6 Aggregate
 TH 19 Driveway/Truck Apron Pavement - 8" Concrete / 6" Class 6 Aggregate
 Local & Frontage Road Pavement - 5" Bituminous / 6" Class 6 Aggregate
 (2) Assumed 6" concrete / 6" aggregate base class 6.
 (3) Parking Areas, City will pay 10% of total parking area and MnDOT will pay 90%.
 (4) Signal Systems: Saratoga - 50/50, Main - MnDOT, Bruce St - 50/50

(5) Assumed 20% MnDOT cost and 80% City cost.
 (6) Includes reinforcement bars.
 (7) Lighting located on City streets; Cost split 4 for City and 8 for MnDOT.
 (8) Based on estimate provided from City.
 (9) Based on preliminary estimate and estimate provided from City. Includes Bruce Street utilities cost.

RESOLUTION NO. _____
Resolution for Layout Approval

At a Meeting of the City Council of the City of _____, held on the ___ day of _____, 20___, the following Resolution was offered by _____ and seconded by _____ to wit:

WHEREAS, the Commissioner of Transportation has prepared a final layout flap for State Project 4204-40 on Trunk Highway 19, from 4th Street to Bruce Street within the City of Marshall for Reconstruction improvements; and seeks the approval thereof, as described in Minnesota Statutes 161.162 to 161.167: and

WHEREAS, said final layout flap is on file in the District 8 Minnesota Department of Transportation office, Willmar, Minnesota, being marked as Layout Flap No. 1A, S.P. 4204-40, from R.P. 34+00.012 to 35+00.514.

NOW, THEREFORE, BE IT RESOLVED that said final layout for the improvement of said Trunk Highway within the corporate limits be and is hereby approved.

Upon the call of the roll the following Council Members voted in favor of the Resolution:

The following Council Members voted against its adoption:

ATTEST:

Mayor _____ Dated _____, 20___

State of Minnesota

County of _____

City of _____

I do hereby certify that the foregoing Resolution is a true and correct copy of a resolution presented to and adopted by the Council of the City of _____, Minnesota at a duly authorized meeting thereof held on the _____ day of _____, 20___, as shown by the minutes of said meeting in my possession.

(SEAL) _____

City Clerk

RESOLUTION No. _____

Resolution for Waiver of Municipal Consent

At a Meeting of the City Council of the City of _____, held on the ___ day of _____, 20___, the following Resolution was offered by _____ and seconded by _____, to wit:

WHEREAS, the Commissioner of Transportation has prepared a final layout for State Project 4204-40 on Trunk Highway 19, from 4th Street to Bruce Street within the City of Marshall for Reconstruction improvements; and seeks the approval thereof, as described in Minnesota Statutes 161.162 to 161.167: and

WHEREAS, said final layout is on file in the District 8 Minnesota Department of Transportation office, Willmar, Minnesota, being marked as Layout Flap No. 1A, S.P. 4204-40, from R.P. 34+00.012 to 35+00.514; and

NOW, THEREFORE, BE IT RESOLVED that the City Council waives the municipal consent approval action, described in Minnesota Statutes 161.162 to 161.167, of the final layout for SP 4204-40 for the improvement of said and Trunk Highway 19 within the corporate limits.

Upon the call of the roll the following Council Members voted in favor of the Resolution:

The following Council Members voted against its adoption:

ATTEST:

Mayor _____ Dated _____, 20___

State of Minnesota

County of _____

City of _____

I do hereby certify that the foregoing Resolution is a true and correct copy of a resolution presented to and adopted by the Council of the City of _____, Minnesota at a duly authorized meeting thereof held on the _____ day of _____, 20___, as shown by the minutes of said meeting in my possession.

(SEAL) _____

City Clerk

**CITY OF MARSHALL
AGENDA ITEM REPORT**

Presenter:	Mayor Brynes
Meeting Date:	Tuesday, October 25, 2022
Category:	COUNCIL REPORTS
Type:	INFO
Subject:	Commission/Board Liaison Reports
Background Information:	<p>Byrnes - Fire Relief Association and Regional Development Commission</p> <p>Schafer – Airport Commission, Joint LEC Management Committee, MERIT Center Commission, SW Amateur Sports Commission</p> <p>Meister – Cable Commission, Community Services Advisory Board, Economic Development Authority</p> <p>Schroeder - Planning Commission</p> <p>DeCramer – Economic Development Authority, Marshall Municipal Utilities Commission, Diversity, Equity, and Inclusion Commission, Public Housing Commission</p> <p>Labat – Adult Community Center Commission, Convention & Visitors Bureau, Library Board, Marshall Area Transit Committee</p> <p>Lozinski – Joint LEC Management Committee, Police Advisory Board</p>
Fiscal Impact:	
Alternative/Variations:	
Recommendations:	

MARSHALL-LYON COUNTY LIBRARY
REGULAR BOARD MEETING MINUTES
SEPTEMBER 12TH, 2022

Board Members Present: Linda Baun, Paula Botsford, Russ Labat, Paul Graupmann, Michael Murray, Eric DeGroot, Ruth Bot, Saara Raappana, and Anne Marie Vorbach. Absent: none. Staff Present: Director Michele A. Leininger, Christine DeGroot, and Paula Nemes. Others Present:

Called to order at 4:00 p.m. by L. Baun, President.

Pledge of Allegiance.

Motion made by P. Graupmann, seconded by R. Bot to adopt the agenda as presented. Voice Vote: Yes- L. Baun, P. Botsford, R. Labat, P. Graupmann, M. Murray, E. DeGroot, R. Bot, and A. Vorbach. No: None. The motion passed unanimously.

S. Raappana arrived.

Motion made by M. Murray, seconded by S. Raappana to adopt the Consent Agenda. Voice Vote: Yes- L. Baun, P. Botsford, R. Labat, P. Graupmann, M. Murray, E. DeGroot, R. Bot, S. Raappana, and A. Vorbach. No: None. The motion passed unanimously.

Old Business:

Update New Employees: The Library recently hired 3 new employees. Jody Kruger is our new Assistant Librarian for Balaton. Emily Spieker is our new Assistant Librarian in Marshall and Kaia Nowatzki is our new customer care employee in Marshall.

IT Update: Over Labor Day weekend, all the computers got moved into the computer lab. All the public computers are now running on Windows 11. On August 29th, the printing software was switched from Pharos to Envisionware. This same software is used on our computer cash register and will now be also used when patrons print and copy. The two coin ops are older and will probably need to be replaced within the next year.

The preservation lab is almost ready for use. The wireless access point in the Community Room quit working. This was the oldest one left in the building so it was replaced by Computer Man.

2023 Final Budget: We decided not to fill the part-time Outreach Librarian position. Instead a fourth Assistant Librarian was hired. This gave us an additional 5 hours a week, along with financial savings. Since the last board meeting, we have been informed of an increase in cost for microfilm, magazines, window washer, and fuel surcharges from several vendors. Motion made by R. Bot, seconded by P. Botsford to adopt the final budget for 2023. Voice Vote: Yes- L. Baun, P. Botsford, P. Graupmann, M. Murray, E. DeGroot, R. Bot, S. Raappana, and A. Vorbach. No: R. Labat. The motion passed by majority vote.

R. Bot leaves.

New Business:

Library Fees & Fines: The room rental rates for different venues in Marshall was reviewed, along with the fines and fees for the different services at the Library. There was a request to find out what other places charges for copies. This topic was tabled for further discuss at the October meeting.

Delivery Van: Motion made by R. Labat, seconded by A. Vorbach to sell the Library van and to put the money in a separate account for the future purchase of a new van. Voice Vote: Yes- L. Baun, P. Botsford, R. Labat, P. Graupmann, M. Murray, E. DeGroot, and A. Vorbach. No: None. The motion passed unanimously.

Policy Review:

Customer Service Philosophy: Motion made by R. Labat, seconded by E. DeGroot to adopt the Customer Service Philosophy with no changes. Voice Vote: Yes- L. Baun, P. Botsford, R. Labat, P. Graupmann, M. Murray, E. DeGroot, and A. Vorbach. No: None. The motion passed unanimously.

Public Posting & Distribution of free Materials: Motion made by P. Graupmann, seconded by R. Labat to adopt the policy with noted change. Voice Vote: Yes- L. Baun, P. Botsford, R. Labat, P. Graupmann, M. Murray, E. DeGroot, and A. Vorbach. No: None. The motion passed unanimously.

E. DeGroot leaves.

Unattended Child/Vulnerable Person: Motion made by M. Murray, seconded by R. Labat to adopt the policy with no changes. Voice Vote: Yes- L. Baun, P. Botsford, R. Labat, P. Graupmann, M. Murray, and A. Vorbach. No: None. The motion passed unanimously.

No Smoking: Motion made by P. Botsford, seconded by R. Labat to adopt the policy with no changes. Voice Vote: Yes- L. Baun, P. Botsford, R. Labat, P. Graupmann, M. Murray, and A. Vorbach. No: None. The motion passed unanimously.

ALA: Freedom to Read/View: Motion made by M. Murray, seconded by A. Vorbach to adopt the updated policy from the ALA. Voice Vote: Yes- L. Baun, P. Botsford, R. Labat, M. Murray, and A. Vorbach. No: P. Graupmann. The motion passed by majority vote.

Reports:

Director's Report – There is a banned book display in the entry way. The final summer reading numbers are 147 adults, 48 teens, 218 kids, and 52 preschool kids. The Read Off Fines program was started this summer. Only a few kids participated in the program. The board agreed to let the staff decide if they want to continue all year or just for the summer months.

Board President Report: None

Friends: They made \$3400 in sales from their Sounds of Summer Book Sale. The following week they opened their book store. They are still going to have two tables in the entryway through the end of the year. They are talking about having a pre-Christmas sale which would include: games, toys, puzzles, large format books, and newer books. They will also be purchasing canvas book bags for patrons to purchase at the front desk. National Library Friends week is October 16th – 22nd.

Board Committees: None.

Plum Creek: They will be having their annual meeting on Wednesday, September 21st at the Tracy Public Library. They will be launching Aspen Discovery on Monday, September 19th. It is an overlay to the current catalog and should help patrons navigate the system better.

Motion by R. Labat, seconded by M. Murray to adjourn at 5:44 p.m.

Respectfully Submitted,
Christine DeGroot

City of Marshall, Minnesota
Cash & Investments
 9/30/2022

	<u>Par</u>	<u>Rate</u>
CASH & INVESTMENTS:		
Checking -Bremer	3,682,706.05	0.00%
Money Market - Bremer	3,498,449.22	0.15%
Money Market - US Bank	1,599,777.57	2.88%
Money Market - Wells Fargo	57,321.04	2.42%
Money Market - 4M	3,009,028.48	2.23%
Certificate of Deposit - Bremer	3,000,000.00	0.40%
Certificate of Deposit - Wells Fargo	1,470,000.00	3.11% Average
Investment Portfolio - General Fund	2,554,066.94	
Investment Portfolio - WW/SW Capital Reserve	3,469,984.07	
Investment Portfolio - Endowment Fund	1,892,807.49	
Municipal - US Bank	5,910,000.00	1.56% Average
Certificate of Deposit - US Bank	1,715,000.00	1.94% Average
Agency - US Bank	5,210,000.00	0.86% Average
Treasury - US Bank	1,000,000.00	2.35%
TOTAL CASH & INVESTMENTS	<u><u>38,069,140.86</u></u>	

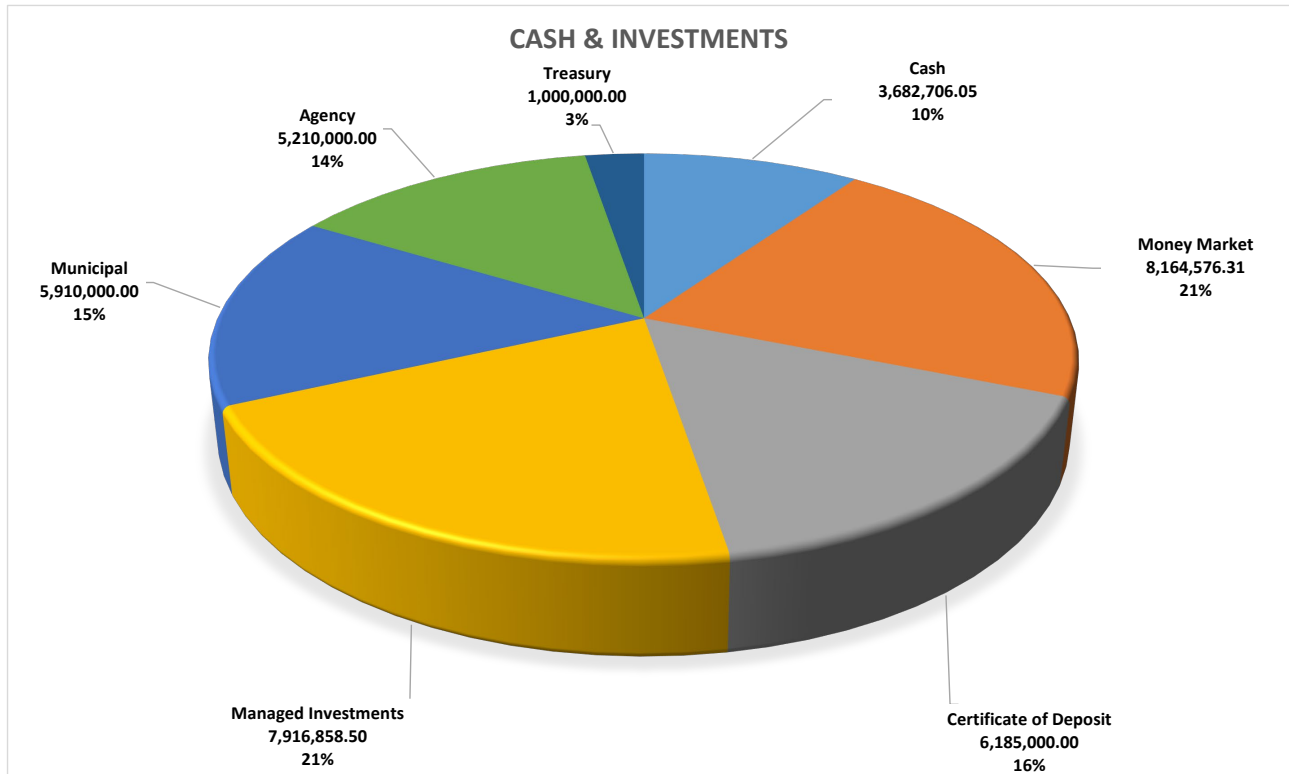

BOARD OF DIRECTORS

Ethel Urbina, *Chairman*
Manuel Ortega, *Vice Chairman*
Rae Hemphill, *Secretary*
Jeanne Van Meter, *Assistant Secretary*
Raymond Sanchez, *Director*
Olga Gonzalez, *Mayor/Ex-Officio Director*



Kissimmee Utility Authority
1701 W. Carroll Street
Kissimmee, Florida 34741-3219
407-933-7777
FAX 407-933-2655

October 4, 2022

City of Marshall
Robert J. Byrnes, Mayor
344 West Main St.
Marshall, MN 56258

Dear Mayor Byrnes,

On behalf of the Kissimmee Utility Authority Board of Directors and our customers, we want to take this opportunity to personally thank you and the dedicated employees of the City of Marshall for your willingness to provide mutual aid support to us while we were bracing for the potential impact of Hurricane Ian. We are grateful for our public power community who comes together to help one another in times of need.

We cannot thank you enough for your quick response to our request. Please know that KUA and most importantly, our citizens, are most appreciative for all your support.

Please express our sincere appreciation to all your officials and workers who traveled to Kissimmee to assist us.

Sincerely yours,

A handwritten signature in blue ink, appearing to read "Ethel Urbina".

Ethel Urbina
Chairman
Kissimmee Utility Authority
Board of Directors

A handwritten signature in blue ink, appearing to read "Olga Gonzalez".

Olga Gonzalez
Mayor/Ex-Officio Director
Kissimmee Utility Authority
Board of Directors

Applicant	Location Address	Description of Work	Valuation
RONALD E & PATRICIA K BIGGAR	504 REDWOOD ST W	Plumbing - Water heater	300
LEE R & JASMINE STEFFEN JT	109 SOUTHVIEW DR W	Plumbing - Water heater	1000
FRANKS ELECTRIC PLUMBING & HEA	501 PAUL ST	Plumbing - Kitchen remodeling	1200
KEVIN GOSLAR TRIO PLUMBING & H	800 COUNTRY CLUB DR	HVAC - [boiler replacement], Furnace	16500
MINNWEST PLUMBING & HEATING IN	1403 ALAN AV	Plumbing - New building	0
REGNIER ELECTRIC HEATING & COO	116 E ST	HVAC - Furnace	3200
KEVIN GOSLAR TRIO PLUMBING & H	800 COUNTRY CLUB DR	HVAC - [boiler replacement]	16500
HARTS HEATING & REFRIGERATION	500 MARSHALL ST W	HVAC - Furnace	3800

Applicant Name	Location Address	Description of Work	Valuation
MARSHALL LUMBER CO	901 ANDREW ST	New Building/House	600000
ADAM N ANTONY & MARSHALL LUMBER CO	1306 PINEHURST RD	Pool	30000
MARSHALL LUMBER CO	807 ANDREW ST	New Building/House	600000
GESKE BUILDING & SUPPLY COMPAN	802 BRUCE ST N	Windows	2100
MICHAEL SLAGEL CONSTRUCTION LL	600 ADOBE RD	Doors	1600
LAYLE FRENCH CONSTRUCTION INC	114 MAPLE ST W	Doors	1000
GESKE BUILDING & SUPPLY COMPAN	107 SOUTHVIEW DR W	Windows	3500
AVERA MARSHALL	300 BRUCE ST S	Interior Remodeling	41460
BRELAND ENTERPRISES INC	807 SILVERVINE DR	Other	15252.31
BRELAND ENTERPRISES INC	1004 SILVERVINE DR	Other	8083.64
JANET B ROCHEL LIVING TRUST	203 ATHENS Unit B	Doors	1400
VANLEEUEWE CONSTRUCTION LLC	809 WESTMAR CR	Re-Roofing	9200
MICHAEL & LYNN CHRISTIANSON JT	402 MAIN ST E	Re-Roofing	6300
GESKE BUILDING & SUPPLY COMPAN	405 CAMDEN DR	Windows	4900
OTTO RENTALS LLC	413 WILLIAMS ST	Re-Roofing	6500
TUTT CONSTRUCTION INC	218 HILL ST N	Interior Remodeling	3000
RANDALL J & VALERIE A KOR JT	622 SOUCY DR	Re-Roofing	5100